

BY SOLAX

**TRIPLE**  
POWER



# TSYS-LD117

## User Manual

Version 1.0

[www.solaxpower.com](http://www.solaxpower.com)



# STATEMENT

---

## Copyright

Copyright © SolaX Power Network Technology (Zhejiang) Co., Ltd. All rights reserved.

No part of this manual may be reproduced, transmitted, transcribed, stored in a retrieval system, or translated into any language or computer language, in any form or by any means without the prior written permission of SolaX Power Network Technology (Zhejiang) Co., Ltd.

## Trademarks



POWER and other symbol or design (brand name, logo) that distinguishes the products or services offered by SolaX has been trademark protected. Any unauthorized use of above stated trademark may infringe the trademark right.

## Notice

All or part(s) of the products, features and services described in this document may not be within your scope of purchase or usage. Unless otherwise specified in the contract, the contents, information and recommendations in this document are provided as is, SolaX makes no kind of warranties, guarantees or representations expressly or implicitly.

The content of the documents is continually reviewed and amended, where necessary. However, discrepancies cannot be excluded. SolaX reserves the right to make improvements or changes in the product(s) and the program(s) described in this manual at any time without the prior notice.

The images contained in this document are for illustrative purposes only and may vary depending on product models.

Please visit the website [www.solaxpower.com](http://www.solaxpower.com) of SolaX Power Network Technology (Zhejiang) Co., Ltd. for more information.

SolaX reserves all the right for the final explanation.

# About This Manual

---

## Scope of Validity

This manual is an integral part of TSYS-LD117. It describes the transportation, storage, installation, electrical connection, commissioning, maintenance and troubleshooting of the product. Please read it carefully before operating.

### Model Code

TSYS-LD117

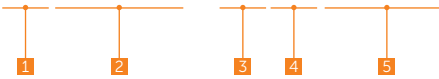

No.	Definition	Description
1	T	Product type: Triple Power
2	SYS	Battery system
3	L	Low-voltage system
4	D	Detached product
5	117	Battery capacity: 11.7 kWh



## Target Group

The installation and maintenance setting can only be performed by qualified personnel who:

- Are licensed and/or satisfy state and local jurisdiction regulations;
- A medium-voltage operator is required to obtain any Certifications for High-voltage Electrician;
- A low-voltage operator is required to obtain any Certifications for Low-voltage Electrician.

## Conventions

The symbols that may be found in this manual are defined as follows.

Symbol	Description
 <b>DANGER</b>	Indicates a hazardous situation which, if not avoided, will result in death or serious injury.
 <b>WARNING</b>	Indicates a hazardous situation which, if not avoided, could result in death or serious injury.
 <b>CAUTION</b>	Indicates a hazardous situation which, if not avoided, could result in minor or moderate injury.
<b>NOTICE!</b>	Provides tips for the optimal operation of the product.

## Change History

### Version 1.0 (2025-12-31)

Updated "[2 Product Overview](#)" (Updated descriptions related to label)

Updated "[8 Capacity and Power Expansion](#)" (Updated the requirements of power cables.)

Updated "[13 Technical Data](#)" (Updated the max discharge current)

### Version 0.0 (2025-07-04)

Initial release

# Table of Content

---

- 1 Safety..... 1
  - 1.1 General Safety.....1
  - 1.2 Battery Safety.....2
  - 1.3 Electrical Safety.....5
- 2 Product Overview.....8
  - 2.1 Introduction..... 8
  - 2.2 Product Appearance ..... 9
    - 2.2.1 System Introduction..... 9
    - 2.2.2 Parts Introduction.....11
  - 2.3 Indicator Panel.....12
  - 2.4 Black Start.....14
  - 2.5 DIP Switch .....14
  - 2.6 LCD Screen .....15
  - 2.7 Label.....21
  - 2.8 Explanation of Symbols and Icons.....22
- 3 Transportation and Storage .....23
  - 3.1 Transportation Requirements..... 23
  - 3.2 Storage Requirements .....24
- 4 Preparation before Installation .....25
  - 4.1 Selection of Installation Location.....25
    - 4.1.1 Installation Environment Requirements.....26
    - 4.1.2 Installation Carrier Requirement .....26
    - 4.1.3 Clearance Requirement.....27
  - 4.2 Installation Option .....27
  - 4.3 Tools Requirement.....28
  - 4.4 Additionally Required Materials.....29
- 5 Unpacking and Inspection.....30
  - 5.1 Unpacking .....30
  - 5.2 Scope of Delivery.....31
- 6 Mechanical Installation.....32
  - 6.1 Floor Mounting .....32
  - 6.2 Wall Mounting .....37

<b>7</b>	<b>Electrical Wiring .....</b>	<b>41</b>
7.1	PE Connection.....	42
7.2	Communication Connection.....	45
7.3	Power Cable Connection.....	47
<b>8</b>	<b>Capacity and Power Expansion.....</b>	<b>50</b>
8.1	Materials Requirements.....	50
8.2	Cable Connection.....	51
8.3	DIP Switch Setting.....	52
<b>9</b>	<b>System Commissioning.....</b>	<b>53</b>
9.1	Checking before Power-on.....	53
9.2	Power on the System.....	53
9.3	Power off the System.....	55
<b>10</b>	<b>Operation on SolaX App and Web .....</b>	<b>57</b>
10.1	Introduction of SolaXCloud .....	57
10.2	Operation Guide on SolaXCloud App.....	57
	10.2.1 Downloading and Installing App.....	57
	10.2.2 Operation on the SolaXCloud App.....	58
10.3	Operations on SolaXCloud Web Page.....	58
<b>11</b>	<b>Troubleshooting and Maintenance.....</b>	<b>59</b>
11.1	Maintenance .....	59
11.2	Troubleshooting .....	60
<b>12</b>	<b>Decommissioning.....</b>	<b>64</b>
12.1	Disassembly of Cables.....	64
12.2	Packing.....	64
12.3	Disposing of the Rechargeable Battery.....	64
<b>13</b>	<b>Technical Data.....</b>	<b>65</b>

# 1 Safety

---

## 1.1 General Safety

Before transporting, storing, installing, operating, using and/or maintaining the device, please carefully read and understand the document, and strictly follow the instructions and safety precautions given herein, as well as symbols affixed on the device. The safety instructions herein are only supplements to local laws and regulations.

The operator should not only abide by all safety precautions provided in the document, including but not limited to the "Danger" sign, "Warning" sign, "Caution" sign, and "Notice" sign, but also comply with relevant international, national and local laws, regulations, standards, guidelines and industry rules in the process of transportation, storage, installation, operation, and maintenance. SolaX will not assume any responsibilities for the loss caused by improper operation, or violation of safety standards for design, production and equipment suitability.

SolaX will not be liable for maintenance for possible device failure, device malfunction, or parts damage, nor will the company assume any liability to pay compensation for the possible physical and property damage resulting from the installation environment that does not meet the design requirements.

The device is well designed and tested to meet all applicable state and international safety standards. However, like all electrical and electronic equipment, safety precautions must be observed and followed during the installation of the device to reduce the risk of personal injury and to ensure a safe installation.

SolaX will not assume any responsibilities if any of the following circumstances occur, including but not limited to:

- Device damage due to force majeure, such as earthquake, flooding, thunderstorm, lighting, fire hazard, volcanic eruption, war, typhoon, tornado, etc.
- Device damage due to human causes.
- Device used or operated against local policy or regulations.
- Failure to follow the operation instructions and safety precautions on the product and in this document.
- Installation and use under improper environment or electrical condition.
- Unauthorized modifications to the product or software.
- Device damage caused during transportation by the customer or the third party.
- Battery damage caused by strong vibrations from external factors before, during and after installation.
- Storage conditions that do not meet the requirements specified in this document.
- Use of incompatible inverters or devices.
- Installation and commissioning operated by unauthorized personnel who are not licensed and/or satisfy state and local jurisdiction regulations.

## 1.2 Battery Safety

### DANGER!

- Do not use SolaX lithium battery in Lead-acid mode. Lead-acid mode not only reduce the lifespan of lithium batteries, but may also cause safety issues under extreme conditions. Any consequences arising from the use of lead-acid mode shall be borne by users themselves, and SolaX will not provide warranty!
- Do not connect the positive and negative poles of a battery together. Otherwise, it may be short-circuited. This will result in an excessive flow of current and large quantities of energy for a short time, and then will cause battery leakage, smoke, the emission of flammable gases, thermal runaway, fire, or even an explosion. Therefore, the battery must be powered off before maintenance.
- If a battery is overheated, it will cause leakage, smoke, release of flammable gases, thermal runaway, fire, or even an explosion. Therefore, please ensure that the installation site shall be well ventilated and kept away from high temperatures.
- Do not dismantle, change, shake, drop, crush, impact, cut, penetrate with a sharp object, or any other ways to damage the battery. Otherwise, it may cause leakage, smoke, emission of flammable gases, thermal runaway, fire, or even an explosion.
- Do not mix different types or makes of the battery. Otherwise, it may cause leakage or rupture, resulting in personal injury or property damage.
- The battery electrolyte is toxic and volatile. Never get in contact with the leaked liquids or inhale gases in the case of the battery leakage or odor, and contact professionals immediately. The professional must wear PPE (including but not limited to safety glasses, safety gloves, gas masks, and protective clothing) before powering off the device, and then contact our company at once after removing the damaged battery.
- Normally, the battery will not release any gases. However, in the following situations: burnt, needle-pricked, squeezed, struck by lightning, overcharged, or subject to other adverse conditions that may cause battery thermal runaway, the battery may be damaged or an abnormal chemical reaction may occur inside the battery, resulting in electrolyte leakage or production of gases. If the battery needs to exhaust flammable gas, safe emission measures must be taken to prevent fire and device corrosion.
- Do not use damaged batteries.

### WARNING!

- Please read the document carefully before installation, operation and maintenance.
- Must arrange fire-fighting equipment in advance according to the local laws, regulations, and standards while installing and commissioning the device.
- Please check that there is no damage to the outer packaging before and after unpacking, and in the process of storage and transportation. The battery shall be correctly placed or stacked in accordance with the requirements stipulated on the labels to prevent damaging or scrapping the battery resulting from crushing or falling.

 **WARNING!**

- Must tighten screws securing cables and on the copper bars according to the torque information specified in the document, and check whether they are tightened periodically. For instance, whether there is any rust, corrosion, or any other foreign object on it, and then clean it up if any. Because the loose screw connections may result in excessive voltage drops and large currents, leading to generating a lot of heat and burning the battery.
- The battery should be charged in time after discharge, to prevent battery damage due to overdischarge. If a battery pack is stored for a long time, please periodically recharge it to protect it from damage according to the storage requirements specified in the document.
- Please charge the battery within the specific temperature range because the low temperature may result in a short circuit. Hence, do not charge it when the temperature is below the low limit of the operating temperature.
- Do not use the battery when you find a bulge, or dents on the battery housing, and contact the installer or professional maintenance personnel to dismantle and replace it. The damaged battery must be kept away from other devices and flammable and explosive articles, and do not contact it except for professionals.
- Before operation, ensure that there are no irritating or burning smells around the battery.
- Do not weld or grind near a battery. Because electric sparks or arcs may cause fires.
- Do not step, lead, stand, or set on the battery.

 **CAUTION!**

- It has the IP40 ingress protection, which allows it to be installed only indoors.

**NOTICE!****Transportation requirements for battery:**

- Relevant qualifications for the transport of dangerous goods must be obtained by the forwarding agent engaged in such businesses, and they must strictly abide by the local regulations for the transport of dangerous goods.
- Please check the battery before transportation. If a battery leaks, smells, or is damaged, do refuse to transport it.
- Please handle gently in the process of loading and unloading, transportation, and moving a battery to prevent bumping, and take effective moisture-proof measures to prevent personal injuries and battery damage.
- Unless otherwise specified, do not transport the batteries, which are classified as dangerous goods, together with food, medicine, or other additives on the same means of transport.

**NOTICE!**

**If the battery leaks electrolyte or any other chemical materials, the electrolyte leakage can lead to toxic gases. Therefore, do not contact with them at all times. In case of accidentally coming into contact with them, please do as follows:**

- In case of inhalation: Leave the contaminated area immediately, and seek medical attention at once;
- In case of contact with eyes: Rinse eyes with running water for at least 15 minutes, and seek medical attention;
- In case of contact with skin: Wash the contact area thoroughly with soap, and seek medical attention;
- In case of ingestion: Induce vomiting, and seek medical attention.

**If a fire breaks out where the battery is installed, please do as follows:**

- In case a battery is charging when the fire breaks out, provided it is safe to do so, unplug the power cable;
- In case a battery is not on fire yet, use a water-based fire extinguisher or a carbon dioxide extinguisher to extinguish the fire;
- In case a battery catches fire, do not try to put it out, and evacuate immediately;
- A battery may catch fire when it is heated above 150°C/302°F. If the battery catches fire, please evacuate immediately since it will generate noxious and poisonous gases.

**Recovery of damaged or wasted battery:**

- Dispose of the damaged or wasted batteries according to local laws and regulations instead of placing them in the household trash or curbside recycling bins. Otherwise, it may cause environmental pollution or explosions.
- Ensure that the damaged or wasted batteries are not exposed to the following situations: high temperatures, high humidity, direct sunlight, or corrosive environments.
- Contact a battery recycling company to scrap the battery, which leaks electrolytes, or is damaged or expired.
- Please take protective steps to prevent battery short circuits before moving batteries.
- Please keep away from flammable material storage areas, residential areas, and other population centers when transporting and storing the damaged battery.

## 1.3 Electrical Safety

### DANGER!

- Please make sure that the unit is free from any damage before the electrical connection.
- Do not modify, change, or dismantle the device.
- Do not change the power-on and power-off sequences and the installation procedure written in the document, and please properly and correctly operate it.
- Do not power on the device during installation. Otherwise, it may cause a fire, personal injury, or device damage.
- Must remove earrings, rings, bracelets, watches, and any other metal jewelry before operation, to avoid electrical shock, burns, or even death.
- During operation, special insulated tools must be used to avoid electric shock or short circuit failure. The insulated tools' voltage ratings must exceed the system voltage ratings. Please refer to "13 Technical Data" for system information.

### WARNING!

- Please wear PPE, such as, protective clothing, insulating shoes, goggles, safety helmets, insulating gloves, etc., when conducting electrical wiring.
- Please check that there is no damage to the outer packaging before unpacking. If damaged, do not use and contact the transporter and manufacturer immediately.
- Do not place installation tools, metal parts and other sundries on the battery while installing. Items on and around it need to be cleaned up in time after finishing installation.
- Do not install the battery in rain, snow, fog and other weather to avoid battery damage.
- If the battery is damaged or accidentally drenched in water, do not install and use it. Please transport it to a safety isolation point and contact the local fire department or professional technicians for scrapping.
- If the battery cables are submerged in water, do not approach, touch or use them.
- Ensure that the positive and negative terminals of the battery are not accidentally grounded. If accidental grounding occurs, disconnect the battery terminals from the ground immediately.
- Do not touch the power supply equipment directly, or through conductors or damp objects.
- Do not touch the parts of the equipment of which warning signs are attached, to avoid personal injury or device damage.

### CAUTION!

- Do not power on the device until it has been installed and confirmed by professionals.
- In the event of a fire, evacuate immediately and call the local fire services.

**NOTICE!**

**General requirement:**

- Please operate according to the safety code for power station.
- Please make sure that the equipment and its associated switches are off before connecting and disconnecting power cables.
- Please check whether the protective housing and insulating sleeve for an electrical component have been installed correctly after finishing installation, to avoid electric shock.
- Must turn off the output switch of the power supply equipment when maintaining its electrical terminal device and power distribution device.
- If the device is required to be powered off during troubleshooting and diagnosis, please do as the following procedure: power off > electricity testing > connecting grounding cable > hanging warning signs and setting up guardrails.
- Must hang up "Do Not Switch On" warning signs on the relevant switches or circuit breakers before completing maintenance, to prevent power connection. Do not switch on before the fault is solved.
- Do not use water, alcohol, oil, or other solvents when cleaning electrical components inside and outside the device.

**Grounding requirement:**

- The device's grounding impedance shall meet the requirements of local electrical safety standards.
- The equipment shall be permanently connected to a grounding wire within the building's electrical system. Please check whether the device is reliably grounded before operation. The grounding cable should be removed last while dismantling and maintaining the device.
- Do not start the device if it is not fitted with a grounding conductor.
- All acts against the grounding conductor are prohibited.
- If the device is equipped with a three-pronged socket, make sure that the ground prong is reliably grounded.
- For the device that may generate large contact currents, please make sure that the grounding terminal on the housing has been grounded before powering on, to avoid electric shock.

**Cable requirement:**

- When deciding the wire diameter, and connecting or wiring cables, follow the local laws, regulations, and codes to ensure safety.
- Before connecting power cables, please make sure that the cable labels are correctly labelled and the cable terminals are well insulated.
- Do not loop and twist cables while conducting electrical wiring. If the length of the power cable is not enough, please replace it instead of joining or welding. Ensure that all the cables of the correct type and size are fully connected and well insulated, and the edges of cable slots and crossing holes are smooth.
- Cables should be kept away from heaters or other heat sources, because a high temperature environment may result in aging and damage to cable insulation.

**NOTICE!****Short circuit protection:**

- Please use electrical tape to wrap the bare conductor cables to prevent short circuits when installing and maintaining the battery.
- Prevent any object from entering into batteries, which may cause a short circuit.
- Regularly check the screws or copper bars on the device, to ensure that they are fully tightened.

## 2 Product Overview

---

### 2.1 Introduction

The TSYS-LD117 is an advanced energy storage system, having the characteristics of high reliability and convenient control. Characteristics are shown as follows:

- Premium LiFePO<sub>4</sub> cells and high-efficiency processors;
- IP40 Protection Level and Protection Class I for reliable and safe operation;
- User-friendly LCD touchscreen for intuitive and easy interaction;
- Remote fault diagnostics and updates;
- Supports floor and wall mounting;
- Expandable to 16 units in parallel;
- CTP (Cell-to-Pack) design maximizes space and energy density for superior performance.

## 2.2 Product Appearance

### 2.2.1 System Introduction

#### System appearance

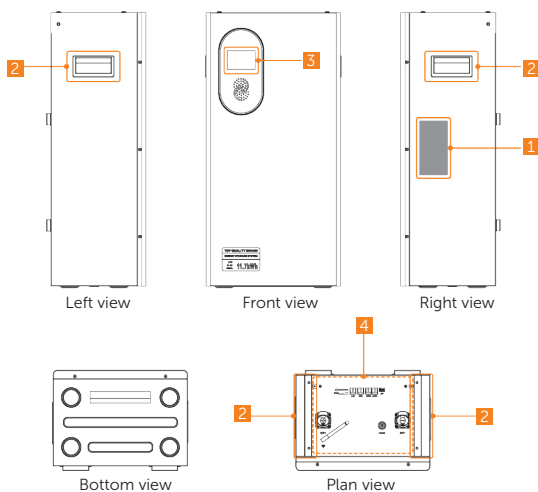

Figure 2-1 Appearance

Table 2-1 Description

No.	Item	Description
1	Label	Including performance information, which clearly identifies the device type, serial number, parameters, certification, etc., and importer information describing name and address of importer. Please refer to "2.7 Label" for details.
2	Handles	Lift the battery conveniently.
3	LCD Screen	Display the information of the battery. For details, please refer to "2.6 LCD Screen".
4	Electrical connection area	Including the <b>BAT+</b> / <b>BAT-</b> ports, communication ports, grounding ports and antenna; the <b>POWER</b> button and Indicator panel. For details, please refer to "2.2.2 Parts Introduction".

### Weight and dimension

Table 2-2 Weight and dimension

	Battery Pack (TB-LD117)
Width (mm)	355
Height (mm)	726
Depth (mm)	263
Net weight (kg)	88

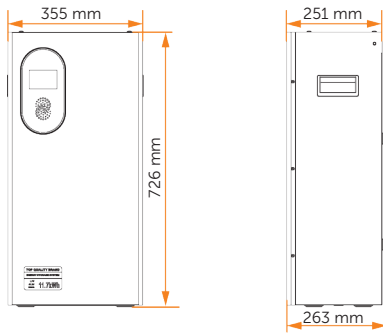

Figure 2-2 Dimension

## 2.2.2 Parts Introduction

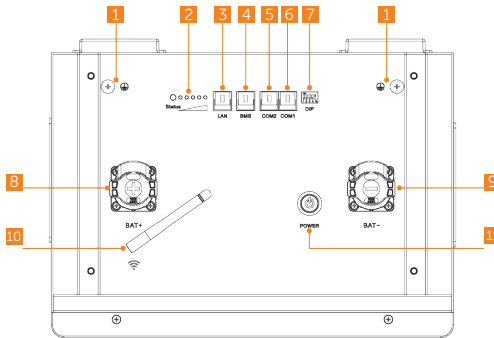

Figure 2-3 Introduction of electrical connection area

Table 2-3 Introduction of electrical connection area

NO.	Item	Description
1	Grounding port	To connect to the grounding port of the inverter or the next battery pack.
2	Indicator panel	Show the operating status and remaining capacity of the battery. Please refer to "2.3 Indicator Panel" for details.
3	LAN port	Communication port: to connect Ethernet cable.
4	BMS port	Communication port: to connect to the <b>BMS</b> port on the inverter.
5	COM2 port	Communication port: to connect to the <b>COM1</b> port on the next battery pack.
6	COM1 port	Communication port: to connect to the <b>COM2</b> port on the previous battery pack.
7	DIP switch	Please refer to "2.5 DIP Switch" for details.
8	BAT+ port	Positive power port: to connect to the <b>BAT+</b> port of the inverter or the parallel box.
9	BAT- port	Negative power port: to connect to the <b>BAT-</b> port of the inverter or the parallel box.
10	Antenna	For WiFi signal.
11	POWER button	To start/shut down system.

## 2.3 Indicator Panel

The battery pack is equipped with a tri-colour status light (yellow/green/red) to show its operating status and five single-colour SOC power indicators (yellow) to show the current battery percentage.

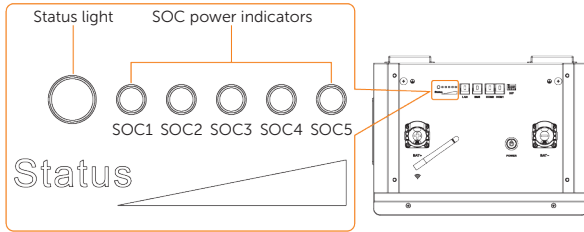

Figure 2-4 Indicators

Table 2-4 Information on indicators

Description	SOC power indicators	Status light
Black start <sup>1</sup>	Yellow, White, Yellow	Yellow flash every 0.8 second
Self test	Solid Yellow	Solid yellow
Standby	Solid Green	Solid green
Charging <sup>2</sup>	Green, White, Green	Green flash every 1 second
Discharging <sup>3</sup>	Green, White, Green	Green flash every 1 second
Shut down	Solid Yellow	Solid yellow to off
Upgrade	Red, Yellow, Green	Red, yellow and green flash in turns
Fault power off	Red, White, Red	Red flash every 3 seconds
Normal power off	Green, White, Green	Green flash every 3 seconds

<sup>1</sup> The battery system will assign each battery pack in a communication loop a unique address (battery number) during this state.

<sup>2</sup> The SOC power indicators will flash yellow, please refer to "SOC power indicators information while charging".

<sup>3</sup> The SOC power indicators will be solid yellow, please refer to "SOC power indicators information while discharging".

### SOC power indicators information while charging

When the battery is charging, SOC power indicators information is shown as follows:

Table 2-5 SOC power indicators information while charging

SOC value	SOC1	SOC2	SOC3	SOC4	SOC5
SOC $\geq$ 80%					
SOC $\geq$ 60%					
SOC $\geq$ 40%					
SOC $\geq$ 20%					
SOC>0%					
SOC=0%					

### SOC power indicators information while discharging

When the battery is discharging, SOC power indicators information is shown as follows:

Table 2-6 SOC power indicators information while discharging

SOC value	SOC1	SOC2	SOC3	SOC4	SOC5
SOC $\geq$ 80%					
SOC $\geq$ 60%					
SOC $\geq$ 40%					
SOC $\geq$ 20%					
SOC>0%					
SOC=0%					

## 2.4 Black Start

The device can provide Black Start capacity, meaning that our energy storage inverter and battery can continue to run even if the power grid and photovoltaic panel are out of service.

The startup procedure for Black Start is as follows:

- If there is only one battery pack, Press and hold the **POWER** button for over five seconds, and release the button when the **Status** light flashes yellow light every 0.8 seconds. The system will assign each battery pack in a communication loop a unique address (battery number). After this has been done, the **Status** light will turn to flashing green. At this point, the system enters discharging status.
- If the system is in parallel with two or more battery packs, Press and hold the **POWER** button of the primary battery pack for over five seconds, and release the button when the **Status** light flashes yellow light every 0.8 seconds. The system will assign each battery pack in a communication loop a unique address (battery number). In the meantime, the **Status** light of the primary battery pack will keep flashing yellow, while the **Status** lights of the secondary packs will flash in turns. After address assignment has been done, the **Status** light of the primary battery pack will turn to flashing green. At this point, the system enters discharging status.

## 2.5 DIP Switch

A DIP Switch is actually a set of small manual electronic switches that are designed to be packaged with other circuits. It is currently equipped with the battery pack.

The location of the **DIP** switch and the factory defaults are shown as below.

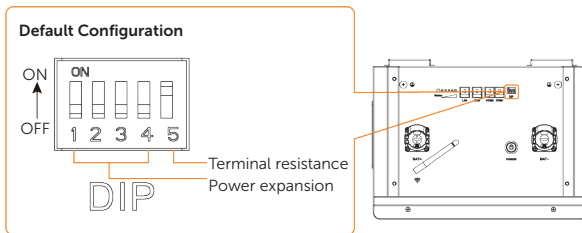

Figure 2-5 DIP switch

There are two circumstances, with details below:

- If there is only one battery pack, keep the **DIP** switch as factory defaults (switch 5 in **ON** position).
- If the system is in parallel with two or more battery packs,
  - » For power expansion, If you connect the system to SolaX inverter, keep the **DIP** switch of all battery packs as by default. You could set it via the inverter screen. For details, see the user manual of inverter.

If you connect the system to the third-party inverter, keep the **DIP** switch 5 in **ON** position and flip the **DIP** switch 1–4 to **ON** position on the primary battery pack (the one connects to inverter). Keep the **DIP** switch of secondary battery packs as by default.

- » For capacity expansion, keep the **DIP** switch of all battery packs as by default.

#### NOTICE!

- To adjust the **DIP** switch, a small flat-head screwdriver should be prepared by the users themselves. **Do not use a pencil**. Graphite from the pencil is conductive and may damage the DIP switch.

## 2.6 LCD Screen

The device is equipped with a LCD (3.5 inches) screen to show the operating status and the related information of the battery. The screen will turn off 15 seconds after no operation.

#### NOTICE!

- The figures of screen display in this section are only taken as examples. Interfaces may vary in different operation status, and the actual interface display shall be prevail in that case.

### Main menu

When the battery starts up successfully, the LCD screen will display the main menu.

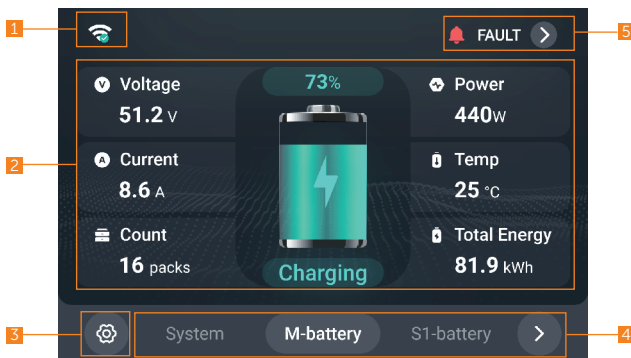

Figure 2-6 Main menu

The main menu mainly contains the following parts:

- (1) WiFi connection status
  - » Display the WiFi connection status.

- » You can touch the icon to turn on or turn off the WiFi connection.
- (2) Battery realtime information
  - » Display the voltage, realtime power, current, temperature, total energy, SOC and state of the battery.
  - » **Count**: number of battery online. Only the **System** page will display the actual data, while other pages will display "/".
  - » When SOC  $\leq 9\%$ , the colour of the battery icon will become red.
- (3) Secondary menu entry
  - » Enter password correctly, you can enter the secondary menu for more information.
- (4) System or battery pack selection
  - » When there is only one battery pack in the system, only **System** and **M-battery** options are displayed.
  - » When there are two or more battery packs, **System**, **M-battery** and **Sn-battery** options are available.
  - » Touch the specific option, the corresponding information will be displayed.
- (5) Fault alarm (if any)
  - » The fault alarm icon appears only when fault occurs. Touch the icon to jump to the detailed fault information page.

## WiFi setting

Touch the WiFi icon of the **System** option on the main menu,

- When there is only one battery pack, it will display as below and you can touch to turn on or off WiFi.



Figure 2-7 WiFi setting (Single battery pack)

- When two or more battery packs are connected, it will enter to a new WiFi array page as below. Touch each icon to turn on or off WiFi of the specific battery pack.

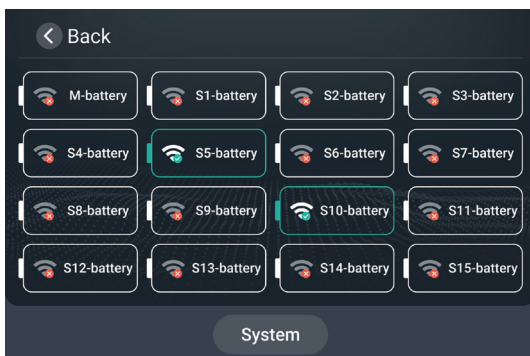

Figure 2-8 WiFi setting (Two or more battery packs)

#### NOTICE!

- When two or more battery packs are connected, the WiFi setting can only be done on the **System** page of the primary battery pack. Other pages of the primary battery pack or pages of the secondary battery pack can only display the connection status.

### Enter password

If you want to enter the secondary menu for more detailed technical data, you need to enter the password on the following page.

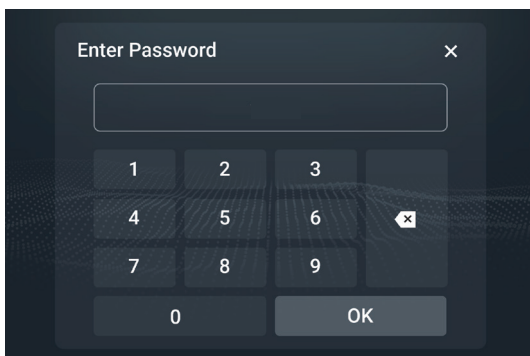

Figure 2-9 Enter password

The default user password is "0000". After entering the password correctly, you can enter the secondary menu:

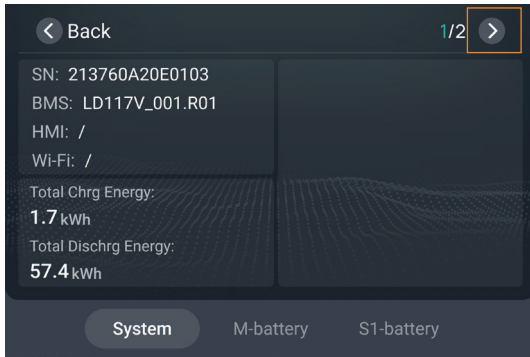

Figure 2-10 Secondary menu

Touch the upper right corner for next page, you can proceed to reset the password or reset the time for password verification. Generally, there is no need to enter the password within 15 minutes after password verification. However, if you touch **Reset Password Time**, the screen will return to the main menu and need to enter the password again for secondary menu.

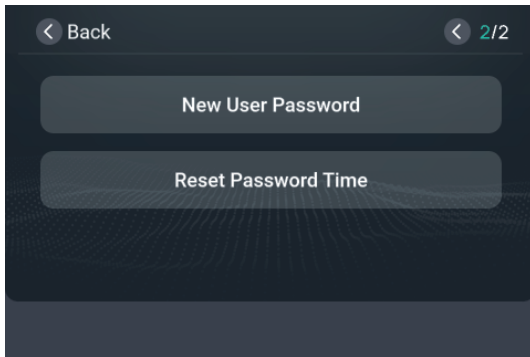

Figure 2-11 Password related options

**NOTICE!**

- More detailed technical information can be accessed under the permissions of installer password. Get the installer password from the dealer and never open the password to unauthorized person.

## Fault

Touch the fault icon on the menu page, you can enter the fault information page.

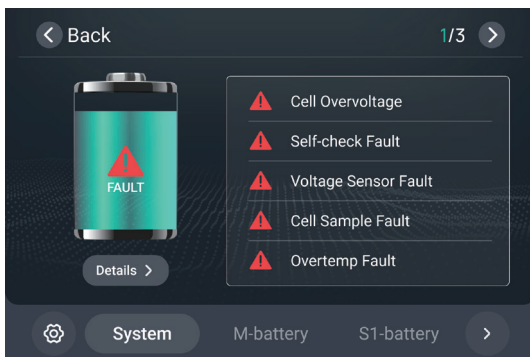

Figure 2-12 Fault page

It displays the latest fault information of the battery, with five records on one page. The options only contain battery packs with error. Touch the specific option to review the information. Please refer to ["11.2 Troubleshooting"](#) for corresponding solutions.

Only System page has an **Details** option, touch to enter the faulty battery array page. On this page, all battery packs will be displayed. If the specific battery pack has no fault, the icon will be green while with fault it would be red. Touch the red icon of faulty battery pack, you can see the detailed information.

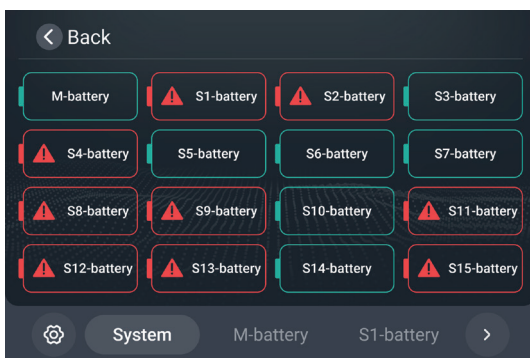

Figure 2-13 Faulty battery array page

### Assigning address

When the system is in the initial startup or black start status, the system will assign address for the battery packs and display the process. After that, it will display **Address assignment completed** and then redirects to the main menu.

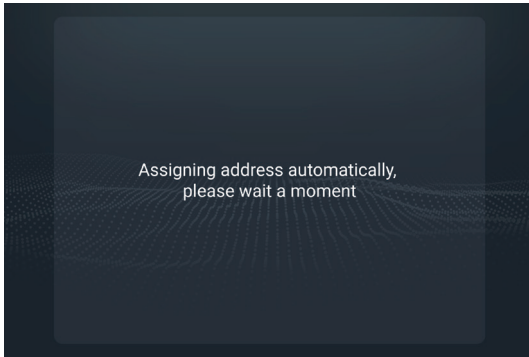

Figure 2-14 Assigning address

### Upgrade

When the system is upgrading, the screen will switch to upgrade page, the upgrade process bar and percentage will be displayed. After the upgrading process, it will display the upgrade is successful or failed and redirects to the main menu five seconds later.

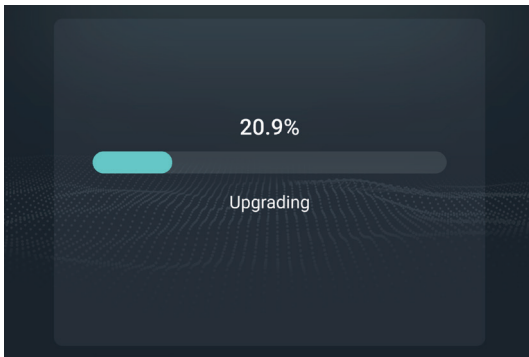

Figure 2-15 Upgrading

## 2.7 Label

Some kinds of labels that contain various technique data or detailed information are pasted on the battery pack. For example, the performance label consists of the following parts:

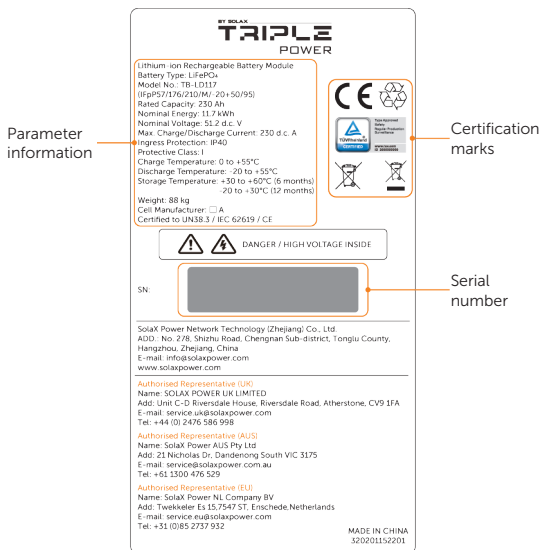

Figure 2-16 System performance label

### Notice!

- Regarding the SN, 32-base nomenclature is adopted to identify the type, specific features, manufacture date, order serial number, and factory serial number.

### 32-base Nomenclature

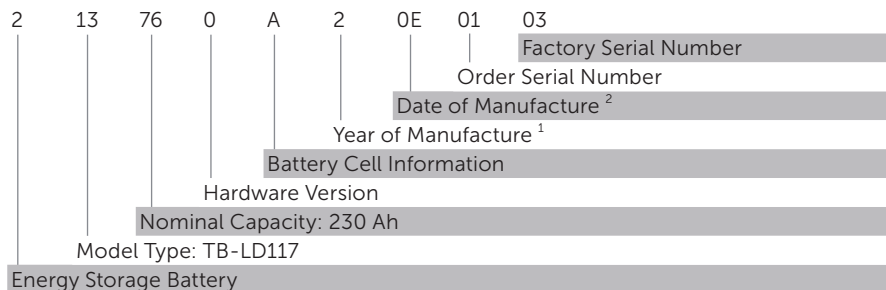













Figure 2-17 Explanation of SN

- 1 0-2023, 1-2024, 2-2025 ..... A-2033, B-2034 .....
- 2 The two digits represent the week of when the battery pack was produced. There are totalling 52 weeks in a year, and the first week is represented by the number 00, and the second week is represented by the number 01. Do the rest in the same manner in accordance with the 32-base coding rule.

## 2.8 Explanation of Symbols and Icons

The meaning of the symbols and icons on the labels is shown as follows:

Table 2-7 Explanation of symbols and icons

Symbol and Icon	Description
	CE mark of conformity.
	TUV certification.
	Protective grounding point.
	The battery module may explode. The rechargeable battery can become hot during operation. Avoid touch during operation.
	Danger, electric shock. Do not touch the device after it is powered on. Otherwise, an electric shock may occur.
	Danger. Due to possible risks, do not touch the device after it is powered on.
	Observe enclosed documentation.
	The device cannot be disposed together with the household waste.
	The device cannot be disposed together with the household waste.
	The battery system must be disposed of at a proper facility for environmentally-safe recycling.
	Keep the device away from children.
	Keep the device from open flames or ignition sources.

# 3 Transportation and Storage

---

## 3.1 Transportation Requirements

### DANGER!

- Please be careful to avoid physical collisions during transportation. Do not place the equipment upside down, be exposed to water, etc., which may result in equipment damage, or even a fire or an explosion.

### CAUTION!

- The battery must be transported in its original packaging. SolaX will not be held responsible for any damage to the battery caused by improper transportation or by transportation after it has been installed.
- Please strictly comply with the transportation requirements of the warning signs on the packaging and equipment.
- Relevant qualifications for the transport of dangerous goods must be obtained by the forwarding agent engaged in such businesses, and they must strictly abide by the local regulations for the transport of dangerous goods. Please check the battery before transportation. If a battery leaks, smells, or is damaged, do refuse to transport it.

### NOTICE!

- Please choose an appropriate transport method based on site conditions and device weight.
- Please wear PPE (e.g. protective gloves, shoes, belt, etc.) and lift the device with proper postures, to prevent personal injuries and device damage.
- Please reasonably arrange the number of workers, the right mix, and the handling position to achieve distributing weight and balancing load when moving the device.
- Please hold the handles or the bottom of the device when moving, to avoid device damage.
- Please pay attention to the surrounding environment when moving, such as, obstacles, slippery ground, etc., to avoid personal injuries and device damage.

### 3.2 Storage Requirements

 **DANGER!**

- The battery must be stored indoors, which the environment should meet the following requirements: 1. Avoiding direct sunlight and keeping out of rain; 2. Dry and well-ventilated; 3. Keeping away from heat and fire sources; 4. Keeping away from radiation; 5. Keeping away from chemicals; 6. Keeping away from dust and metal conductive dust; 7. Being equipped with fire facilities.
- Batteries must be stored in accordance with the requirements of the warning signs and other information on the packaging.
- Do not store with any other electronic equipment, chemicals, or other items that may cause interference or danger.
- Please pay attention to the height when stacking batteries to avoid deforming or damaging the battery at the bottom.

**Notice!**

- Store the device according to the signs on the packaging.
- Do not store the batteries for a long time. If long periods of storage are unavoidable, please recharge it periodically to avoid battery damage.
- If the battery has been stored for more than 1 year, it must be checked and tested by professionals before use.
- The relative humidity should be between 5% and 95%.
- It is recommended to store the battery in a temperature range of -20°C to +60°C.

Table 3-1 Storage temperature and recharge time

Storage temperature range	Storage time
+30°C to +60°C	Every 6 months.
-20°C to +30°C	Every 12 months.

# 4 Preparation before Installation

---

## 4.1 Selection of Installation Location

### NOTICE!

- Since the operating temperature affects the operation and service life of a battery, please install it in an appropriate ambient environment.
- The operating ambient temperature for the battery is between  $-20^{\circ}\text{C}$  and  $+55^{\circ}\text{C}$ .
- The discharge current will be reduced when the temperature of the battery cell is between  $-20^{\circ}\text{C}$  and  $+5^{\circ}\text{C}$  or between  $+45^{\circ}\text{C}$  and  $+55^{\circ}\text{C}$ . And the charge current will be reduced when the temperature of the battery cell is between  $0^{\circ}\text{C}$  and  $+20^{\circ}\text{C}$  or between  $+45^{\circ}\text{C}$  and  $+55^{\circ}\text{C}$ .

The installation location selected for the rechargeable battery is quite critical in the aspect of the guarantee of machine safety, service life and performance.

- The selection of installation sites must strictly comply with local laws, regulations, and related industry standards;
- Fire extinguishers must be configured at the installation site according to the local fire codes;
- Flaunting an IP40 enclosure, the battery can be used only indoors;
- The installation site shall be convenient for wiring connection, operation and maintenance;
- During the planning phase, please consider the space for capacity expansion or power expansion in the future;
- Good transportation for the installation site;
- Do not install devices on the undesirable soil that are prone to deformation and settlement;
- Since the salt-damaged and polluted areas may corrode the device, the device must keep away from these areas.

### 4.1.1 Installation Environment Requirements

Make sure the installation site meets the following conditions:

- Ambient temperature: -20°C to +55°C;
- Relative humidity: 5–95%RH
- Altitude: Below 3000 meters;
- Good ventilation;
- Keep away from combustibles;
- Keep away from antenna;
- Keep away from inflammable and explosive materials;
- Keep away from corrosive substances.

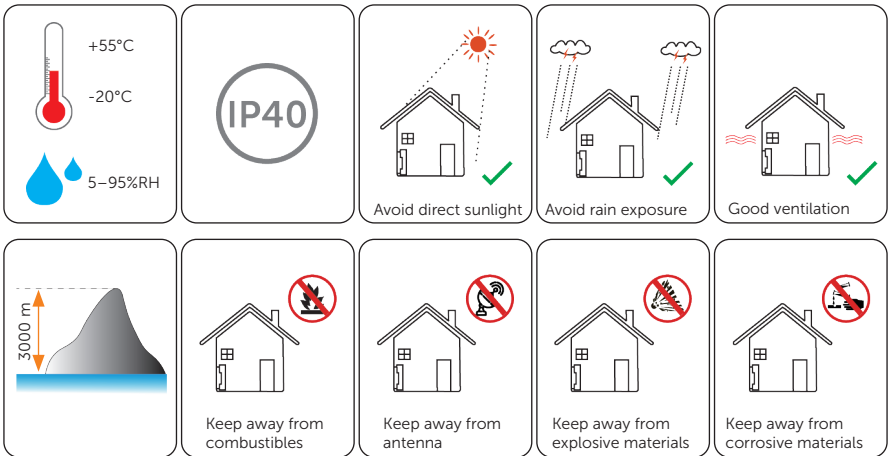

Figure 4-1 Environment requirements

### 4.1.2 Installation Carrier Requirement

The mounting location must be suitable for the weight and dimensions of the product and the support surface for installation must be made of a non-flammable material. Detailed requirements are shown below:

- The installation floor and wall shall be made of non-combustible materials, such as solid brick, concrete, and the surface shall be level, firm, and flat with a sufficient load-bearing capacity;
- Please ensure that the installation site has a bearing capacity of at least 4 times the weight of the entire battery system;
- Please ensure that the thickness of any part of the wall is no less than 100 mm;
- The product must not be installed on the wood wall.

### 4.1.3 Clearance Requirement

To guarantee proper heat dissipation and ease of disassembly, the minimum space around the rechargeable battery must meet the standards indicated below. Regardless of the installation options and number of battery packs,

- A distance between 200 and 300 mm wide shall be provided from the wall to the edge of the battery pack.
- A distance between 400 and 600 mm wide shall be provided from the left side edge of a battery pack to the right side edge of the neighbouring battery packs.

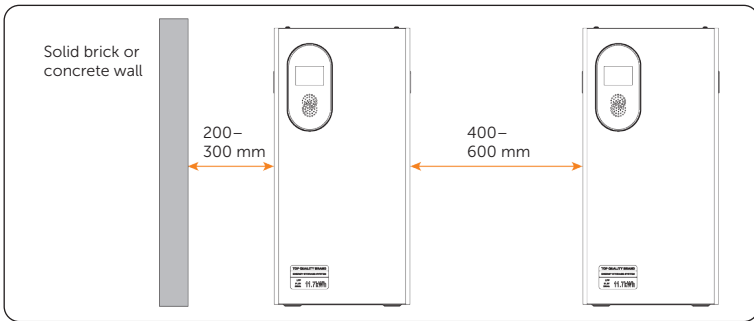

Figure 4-2 Installation clearance

## 4.2 Installation Option

There are two options: floor mounting and wall mounting. Below figures take two battery packs as example.

- Option A: Floor mounting

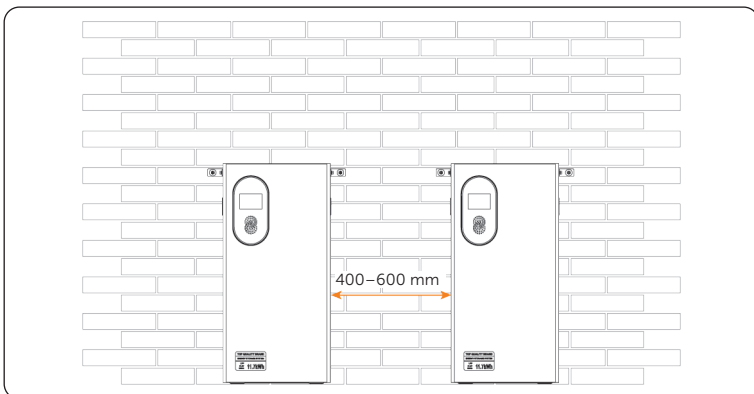

Figure 4-3 Floor mounting

- Option B: Wall mounting

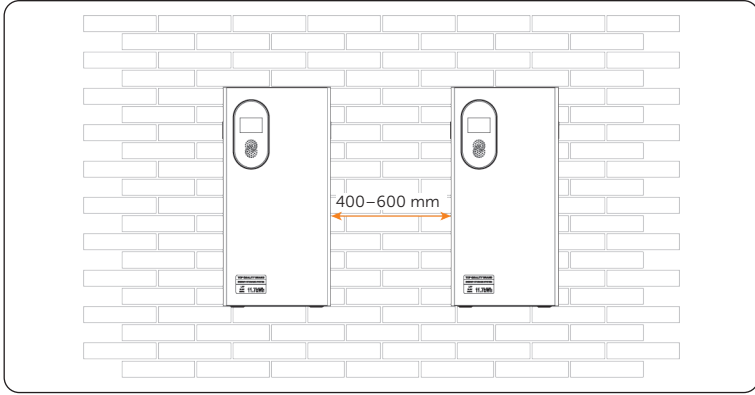
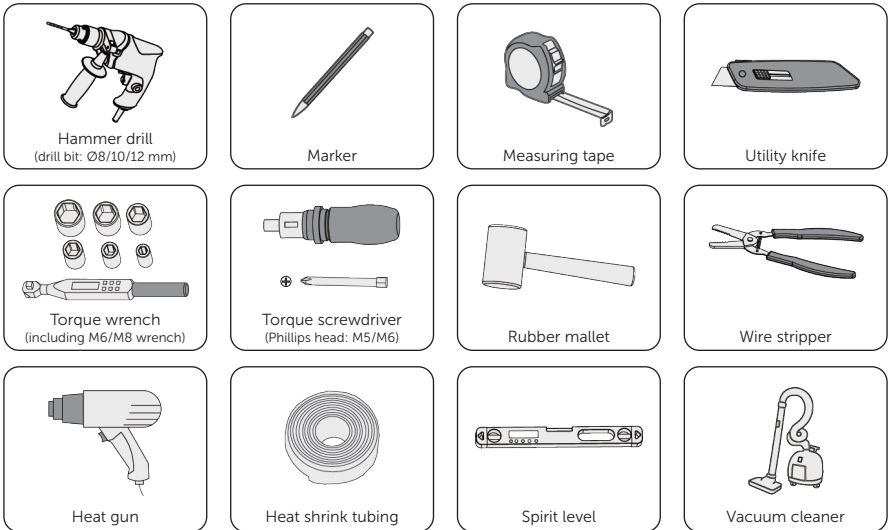

Figure 4-4 Wall mounting

### 4.3 Tools Requirement

Installation tools include but are not limited to the following recommended ones. If necessary, use other auxiliary tools on site.

#### Installation tools



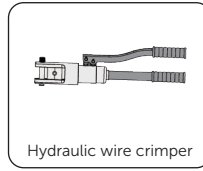
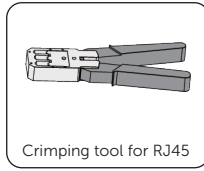
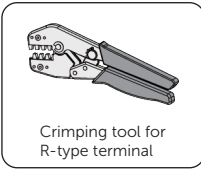



### Personal protective device



## 4.4 Additionally Required Materials

Table 4-1 Additionally required wires

No.	Required Material	Type	Conductor Cross-section
1	Additional PE cable	 Conventional yellow and green wire	25 mm <sup>2</sup>
2	Ethernet cable (Optional)	 CAT-5	/
3	Ethernet cable connector (Optional)	 RJ45 plug	/

# 5 Unpacking and Inspection

## 5.1 Unpacking

- The rechargeable battery undergoes 100% testing and inspection before shipping from the manufacturing facility. However, transport damage may still occur. Before unpacking the rechargeable battery, please verify that the model and outer packing materials for damage, such as holes and cracks.
- Unpack a battery pack according to the following figure.

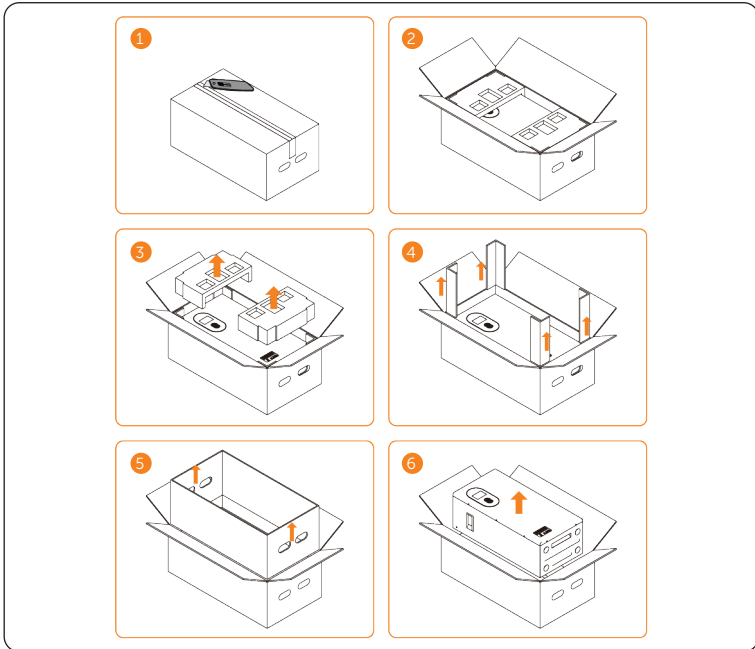
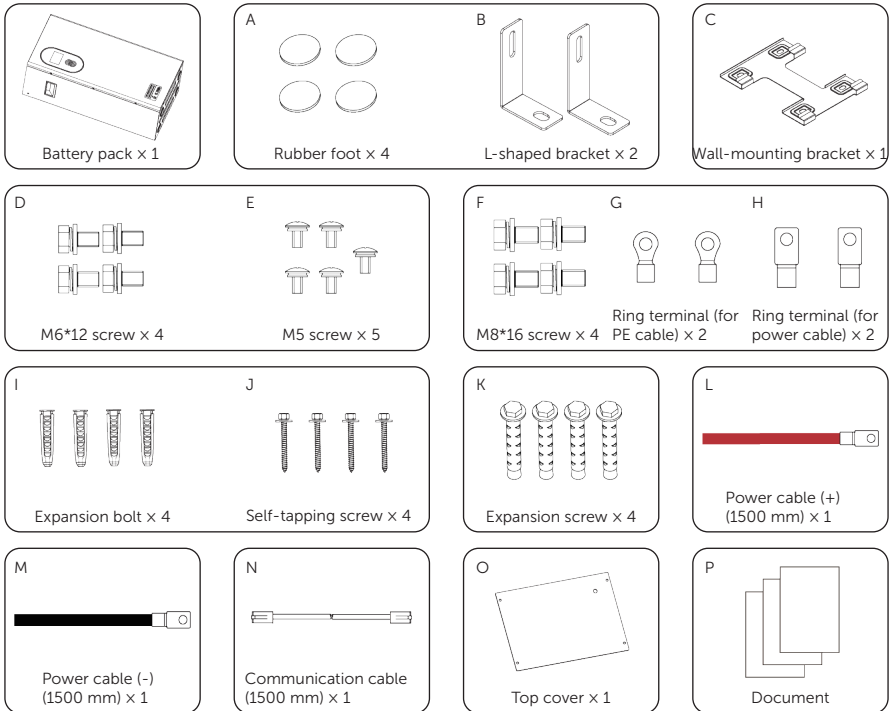

Figure 5-1 Unpacking the battery pack

- Be careful when dealing with all package materials which may be reused for storage and relocation of the rechargeable battery in the future.
- Upon opening the package, check whether the appearance of the rechargeable battery is damaged or lack of accessories. If any damage is found or any parts are missing, contact your dealer immediately.

## 5.2 Scope of Delivery



# 6 Mechanical Installation

## WARNING!

- Only the qualified personnel can perform the mechanical installation following the local standards and requirements.
- Check the existing power cables or other piping in the wall to prevent electric shock or other damage.
- Use insulated tools and wear personal protective device (PPE) during installation and maintenance.

## CAUTION!

- Pay attention to the weight of the device at all times during transportation and installation, as improper lifting or dropping of the device may cause personal injury.

## NOTICE!

- Please ensure that the occupied floor area's bearing capacity for the device is over four times the total weight.
- Please ensure that the thickness of any part of the wall is  $\geq 100$  mm;
- The product must not be installed on the wood wall.

There are two options for installation (floor mounting and wall mounting), you can choose based on your needs. No matter which option is chosen, up to 16 battery packs can be connected in one system.

The following descriptions will mainly take one pack as an example.

## 6.1 Floor Mounting

**Step 1:** Stick the rubber feet (Part A) to the bottom of the battery pack.

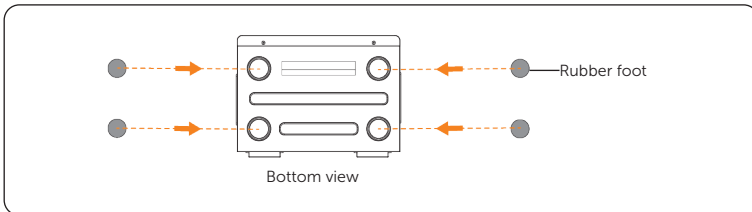

Figure 6-1 Sticking the rubber feet

**Step 2:** Attach the L-shaped brackets (Part B) to both sides of the battery pack with M6\*12 screws (Part D), but do not tighten fully.

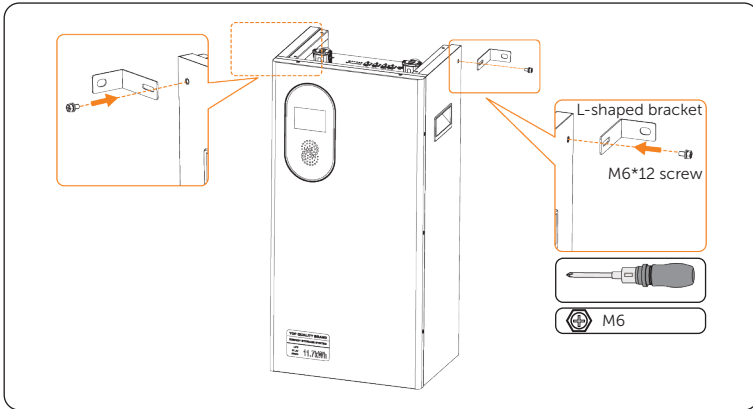

Figure 6-2 Attaching the L-shaped brackets

**Step 3:** Locate the L-shaped brackets against the wall.

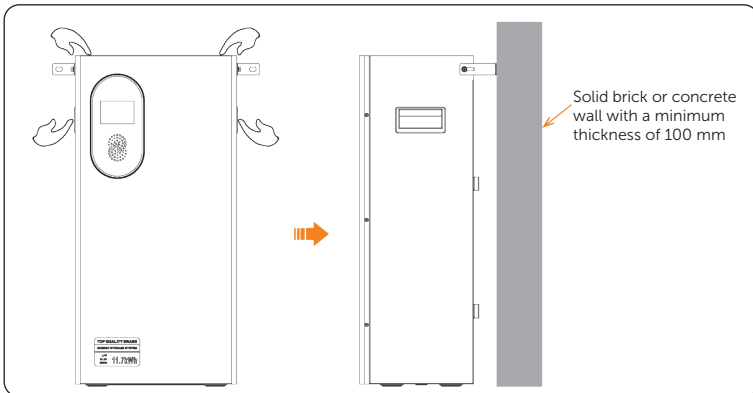

Figure 6-3 Locating the battery pack against the wall

#### NOTICE!

- At least two persons are required to move the battery pack. When moving the battery pack, please put your hands on the top and side handles and pay attention to the weight of the battery pack.

**Step 4:** Draw a circle along the inner ring with one on each side of the L-shaped bracket. Then gently move the battery pack aside.

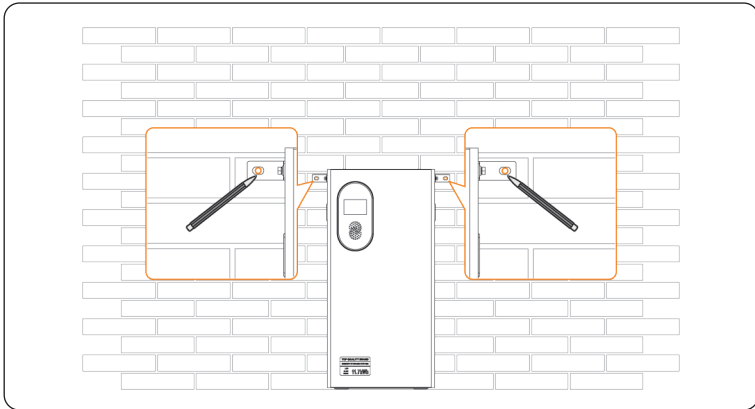

Figure 6-4 Drawing circles

**Step 5:** Drill two holes at a depth of more than 60 mm in the concrete wall (or solid brick wall) by using hammer drill ( $\text{Ø}8$  and  $\text{Ø}10$  mm).

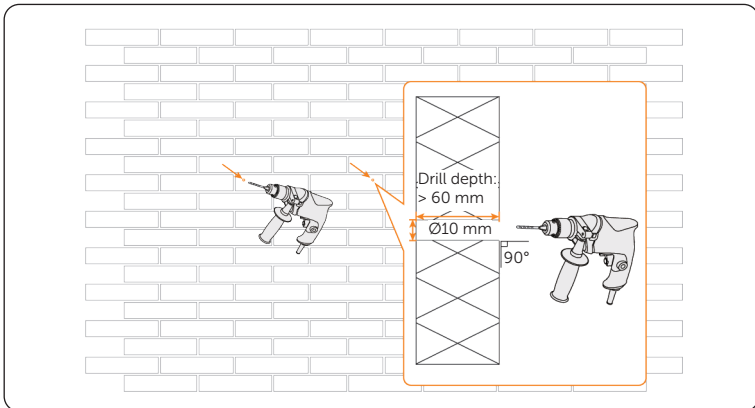

Figure 6-5 Drilling holes

**NOTICE!**

- Use the package bag of the battery pack or other materials to fully cover it to prevent dust during drilling.
- To prevent angled holes from being drilled, it is suggested to use a  $\text{Ø}8$  mm drill to drill holes first, and then change to a  $\text{Ø}10$  mm drill.
- Please clean the dust on the wall and foundation timely after drilling.

**Step 6:** Insert the expansion bolts (Part I) by using rubber mallet, and ensure that the entire expansion bolt is driven into the wall. (Expansion bolt: 2 pieces)

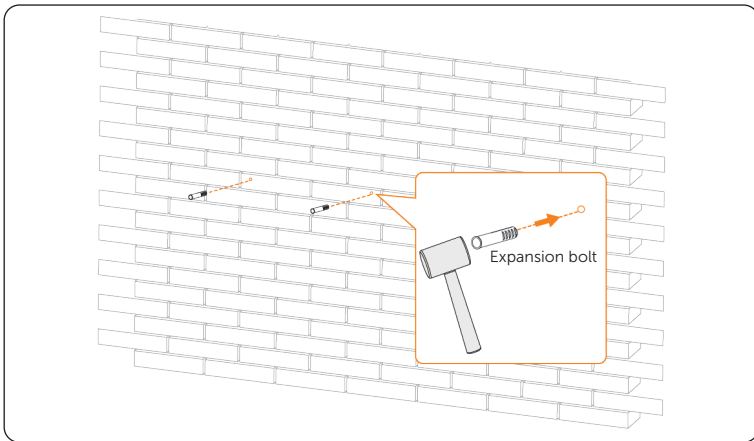

Figure 6-6 Inserting expansion bolts

**Step 7:** Gently move the battery pack against the wall and align the holes drilled previously. Correctly insert and tighten the self-tapping screws (Part J) to secure the L-shaped bracket on both sides to the wall (Tightening torque: 6–8 N·m). Fully tighten M6 screw on both sides (Tightening torque:  $3 \pm 0.3$  N·m).

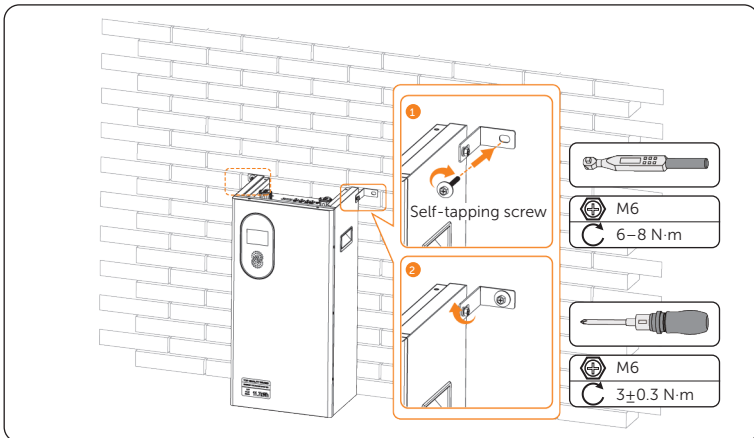

Figure 6-7 Tightening self-tapping screws and M6 screws

**Step 8:** If two or more battery packs are to be installed, repeat steps 1 to 7 to install the second battery pack, as well as the remaining battery packs.

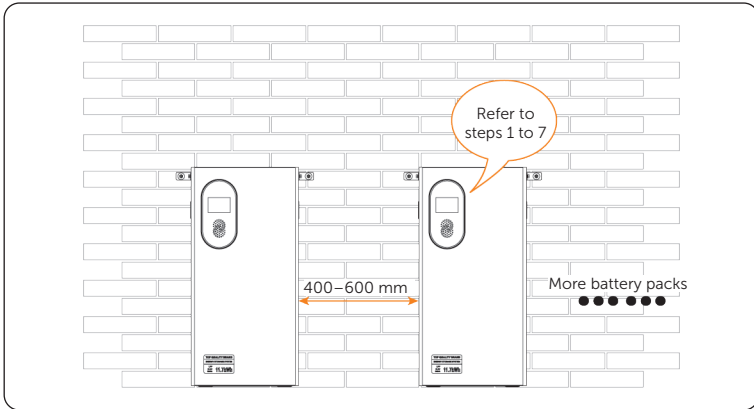

Figure 6-8 Installing the remaining battery pack(s)

**NOTICE!**

- A distance between 400 and 600 mm wide shall be reserved from the left side edge of a battery pack to the right side edge of the neighbouring battery pack.
- Up to 16 battery packs can be installed in a straight line.

## 6.2 Wall Mounting

**Step 1:** Stick the rubber feet (Part A) to the bottom of the battery pack.

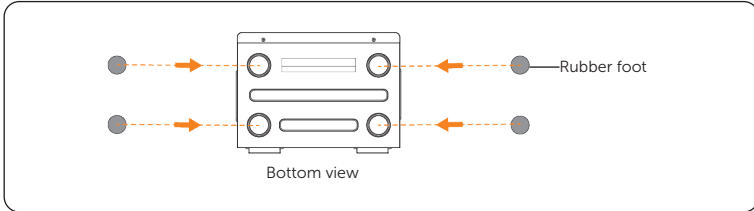

Figure 6-9 Sticking the rubber feet

**Step 2:** Attach the wall-mounting bracket (Part C) to the wall; make sure that the bracket is at least 200 mm above the ground and it is level with a spirit level. Draw circles along the inner rings of the bracket, with a total of 4 circles.

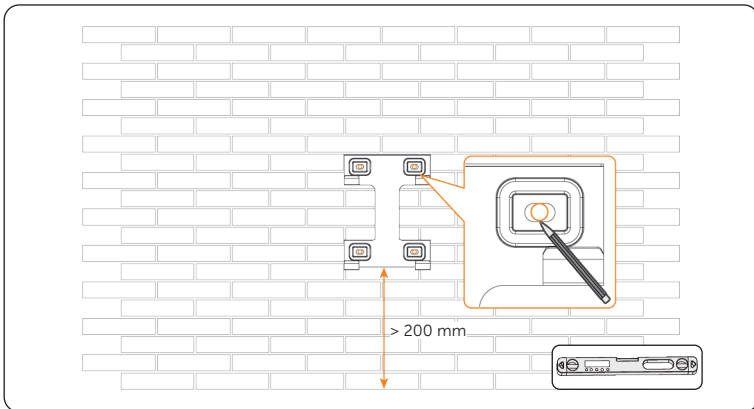

Figure 6-10 Drawing circles

**Step 3:** Remove the wall-mounting bracket and drill four holes at a depth of more than 90 mm in the concrete wall (or solid brick wall) by using hammer drill ( $\text{\O}10$  and  $\text{\O}12$  mm).

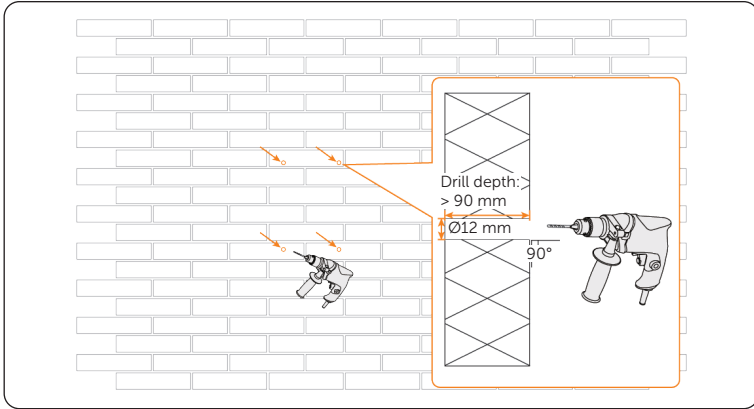

Figure 6-11 Drilling holes

**NOTICE!**

- Use the package bag of the battery pack or other materials to fully cover it to prevent dust during drilling.
- To prevent angled holes from being drilled, it is suggested to use a  $\text{\O}10$  mm drill to drill holes first, and then change to a  $\text{\O}12$  mm drill.
- Please clean the dust on the wall and foundation timely after drilling.

- Step 4:** Align holes of the wall-mounting bracket with holes drilled previously. Insert the expansion screws (Part K) by using rubber mallet first, and then secure the screws with a torque wrench (Tightening torque: 14–16 N·m).

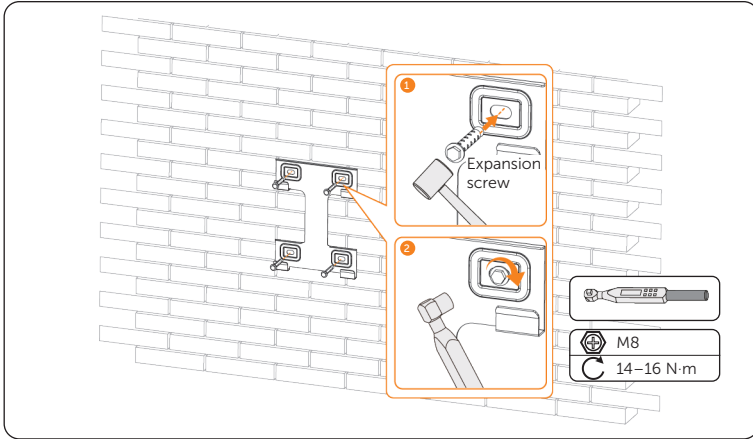

Figure 6-12 Tightening expansion screws

- Step 5:** Lift the battery pack and hang it onto the wall-mounting bracket.

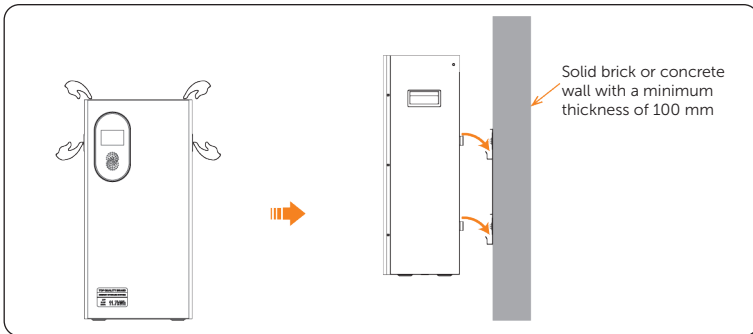

Figure 6-13 Hanging the battery pack on the wall-mounting bracket

#### NOTICE!

- At least two persons are required to lift the battery pack. When lifting the battery pack, please put your hands on the top and side handles and pay attention to the weight of the battery pack.

**Step 6:** If two or more battery packs are to be installed, repeat steps 1 to 5 to install the second battery pack, as well as the remaining battery packs

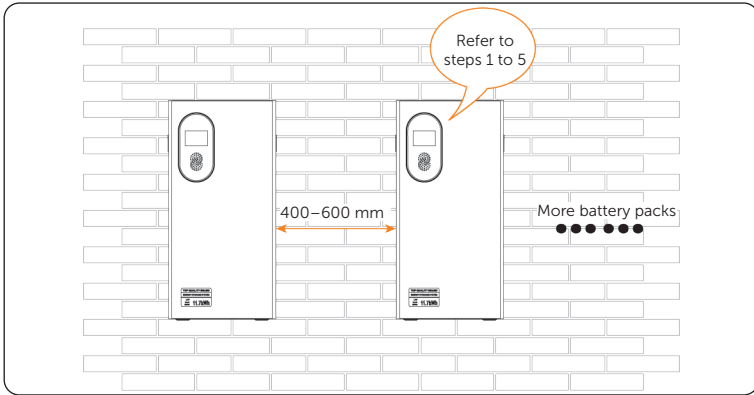

Figure 6-14 Installing the remaining battery pack(s)

**NOTICE!**

- A distance between 400 and 600 mm wide shall be reserved from the left side edge of a battery pack to the right side edge of the neighbouring battery pack.
- Up to 16 battery packs can be installed in a straight line.

# 7 Electrical Wiring

## DANGER!

- Make sure that the battery and inverter are shut down before wiring.

## WARNING!

- Only the qualified personnel can perform the wiring.
- Follow this manual to wire connection. The device damage caused by incorrect cabling is not in the scope of warranty.
- Use insulated tools and wear individual protective tools when connecting cables.

## CAUTION!

- It's important to give the cables a health check before connection.

## NOTICE!

- Select appropriate cable size and circuit breaker protection on the battery side based on the overload current of 250 A.

Cables between the battery pack and inverter, as shown in the following figure.

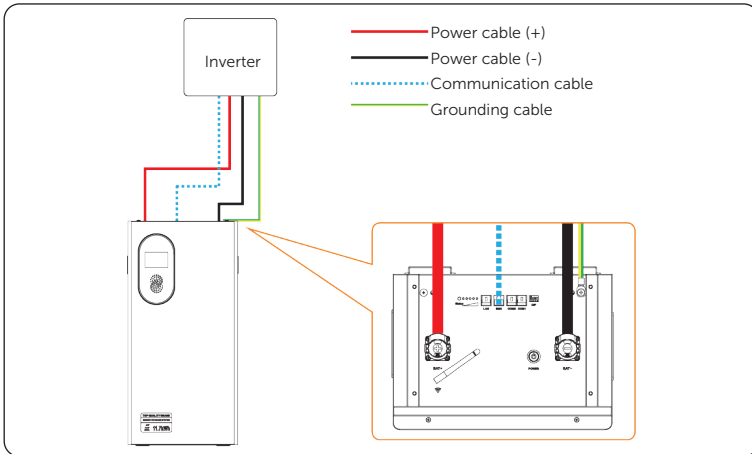

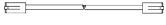



Figure 7-1 Wiring diagram

Regarding the cables shown in the Figure 7-1, see the following table.

Table 7-1 Cable information

Cable	Length	Description
Power cable (+) (standard) 	1500 mm	<b>BAT+</b> port of battery pack to <b>BAT+</b> port of inverter
Power cable (-) (standard) 	1500 mm	<b>BAT-</b> port of battery pack to <b>BAT-</b> port of inverter
Communication cable (standard) 	1500 mm	<b>BMS</b> port of battery pack to <b>BMS</b> port of inverter
Grounding cable	/	 port of battery pack to  port of inverter Please refer to "4.4 Additionally Required Materials" for details.

**NOTICE!**

- The end of cables that will be connected to inverters are bare upon delivery with the battery, and need external connector for connecting inverters.

**NOTICE!**

- For wiring with two or more battery packs, please refer to "8 Capacity and Power Expansion".

## 7.1 PE Connection

**! DANGER!**

- Make sure that the PE cable is securely connected.
- Failure to follow these instructions can result in death or serious injury.

The steps for making PE connection are shown as follows:

**Step 1:** Strip the cable jacket about 12 to 15 mm from the end.

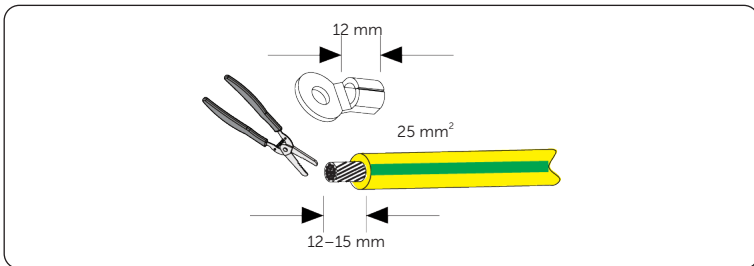

Figure 7-2 Stripping cable jacket

**NOTICE!**

- It's necessary to use controlled motion to strip the insulation down the wire, to prevent damage to the wires.
- Make sure that the insulation layer has been stripped to a sufficient length so that the center conductor is fully exposed without any damage or nicks. In addition, make sure that no extra insulation remains beyond the connector once it's crimped on.

**Step 2:** Cut the heat shrink tubing to about 28 to 30 mm length, carefully slide it onto the end of the cable, and then carefully slip the wires all the way into the ring terminal (Part G).

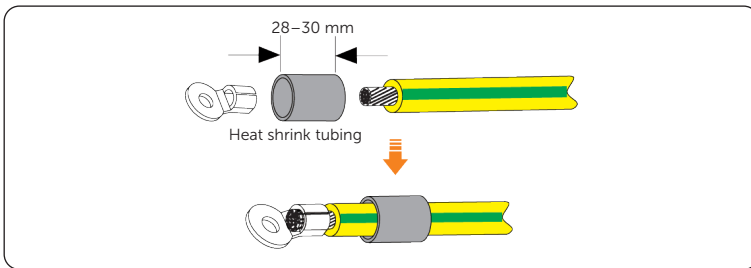

Figure 7-3 Cutting heat shrink tubing

**Step 3:** Crimp the terminal, and heat the heat shrink tubing after it wraps the end of terminal.

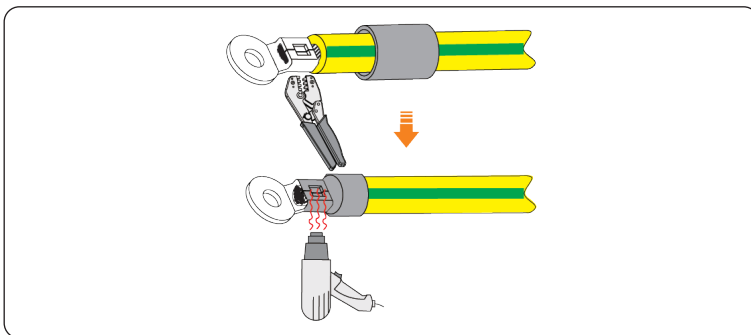

Figure 7-4 Crimping and heating

**NOTICE!**

- Do not place the conductor insulation into the terminal.
- Do not damage the conductor insulation while crimping.
- Move the heat gun back and forth slowly to distribute the heat evenly across the surface of heat shrink tubing.

**Step 4:** Unscrew the M5 screw, connect the assembled PE cable to the grounding port of the battery pack, and then tighten M5 screw. (Tightening torque: 2.5–3 N·m). There are two grounding port on the battery pack, connect based on your actual need.

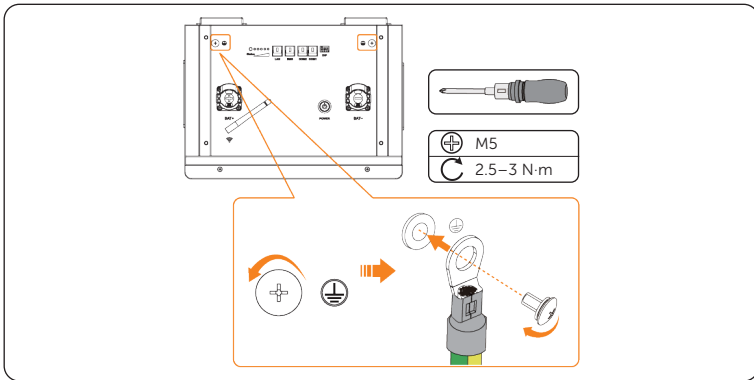

Figure 7-5 Connecting PE cable and tightening M5 screw

## 7.2 Communication Connection

### Pin assignment

The wire sequence is shown as follows:

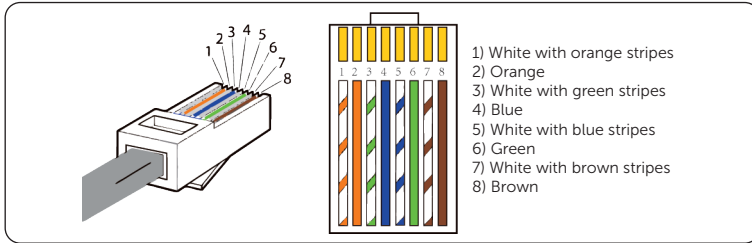

Figure 7-6 Wire sequence

The pin assignment of **BMS**, **COM1** and **COM2** ports is shown as follows:

Table 7-2 BMS port pin assignment

Pin	1	2	3	4	5	6	7	8
BMS	RS485B	RS485A	GND	CAN-H	CAN-L	/	MASTER-IN	/

Table 7-3 COM1 port pin assignment

Pin	1	2	3	4	5	6	7	8
COM 1	Up out	GND	Wake up	CAN-H	CAN-L	Up in	/	GND

Table 7-4 COM2 port pin assignment

Pin	1	2	3	4	5	6	7	8
COM 2	Next in	GND	Wake up	CAN-H	CAN-L	Next out	/	GND

#### NOTICE!

- Communication cable (Part N) is applicable for **BMS**, **COM1** and **COM2** ports. If Ethernet connection is needed, please prepare Ethernet cable to connect on **LAN** port according to your needs.
- When you need to make communication cable(s) on your own, please strictly follow the pin definitions.

### Connection procedure

**WARNING!**

- To ensure normal operation between the battery pack and inverter, make sure that the **BMS** port on the battery pack connects to **BMS** port on the inverter pin-to-pin.

The connection procedure for **BMS**, **COM1**, **COM2** and **LAN** ports are basically the same. Here take **BMS** port as an example in the following figure.

Remove the waterproof cap of the corresponding port and connect the communication cable as needed.

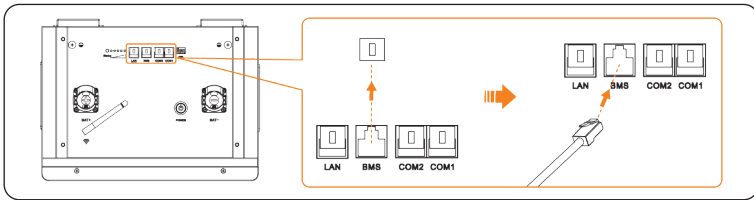

Figure 7-7 Connecting communication cable (an example)

## 7.3 Power Cable Connection

### NOTICE!

- Power cables (Part L and Part M) are delivered with the battery pack with ring terminal installed on one end (for connecting battery side), and you need to install ring terminal for power cable on the other end before connecting power cables.
- You can use the ring terminals (Part H) from the accompanied accessory of the battery pack or the ring terminals delivered with the inverter or self-prepared ring terminal based on your actual need. When preparing ring terminals on your own, please strictly follow the local regulations.

**Step 1:** Cut the negative power cable into appropriate length with care based on the actual installation distance. And then strip the cable jacket about 10 mm from the end.

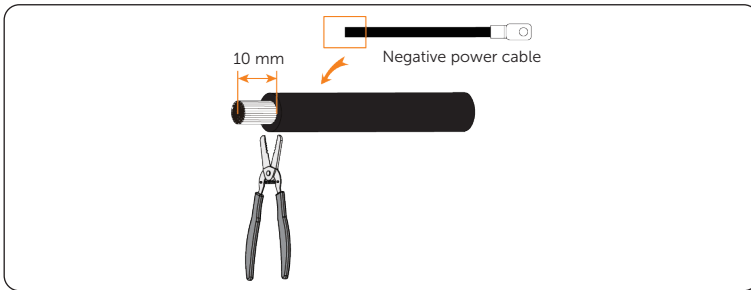

Figure 7-8 Stripping power cable

### NOTICE!

- DO NOT damage the conductor while sliding the jacket off the power cable end.
- The wire size of the power cable delivered with the device is 70 mm<sup>2</sup> (UL10269 2/0 AWG).

**Step 2:** Cut the heat shrink tubing to about 15–20 mm long, slide it onto the end of the cable, and then slip the cable all the way into the ring terminal.

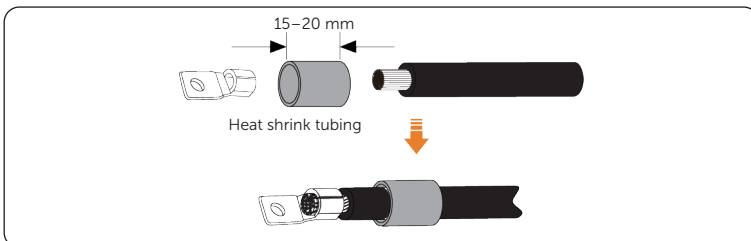

Figure 7-9 Installing heat shrinking tubing

**Step 3:** Crimp the terminal, and pull the heat shrink tubing over the ring terminal and use a heat gun to shrink it so that it can be firmly contacted with the terminal.

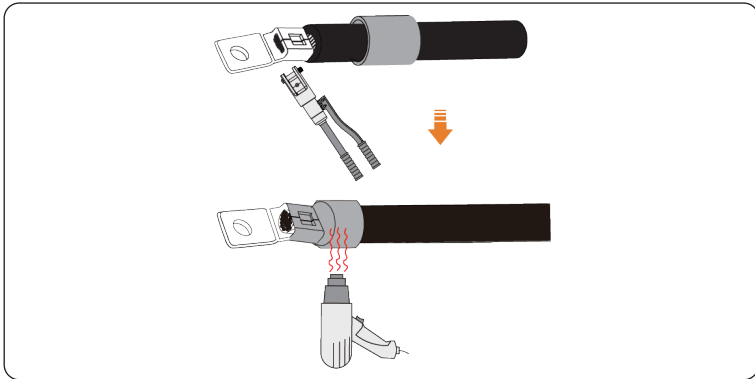

Figure 7-10 Crimping and heating terminal

**NOTICE!**

- Properly place the ring terminal into the hydraulic wire crimper.

**Step 4:** Make the positive power cable according to above steps.

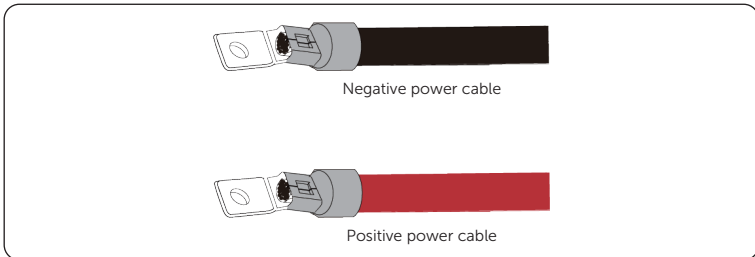

Figure 7-11 Making the positive cable

**Step 5:** Remove the terminal caps on the **BAT+** and **BAT-** ports, then align the power cables with the ports.

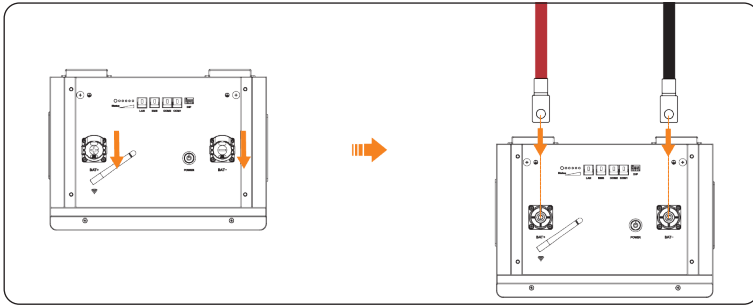

Figure 7-12 Connecting power cables

**Step 6:** Secure the power cables with M8\*16 screws (Part F) (Tightening torque:  $7 \pm 0.5$  N·m). Then re-install the terminal caps on the ports.

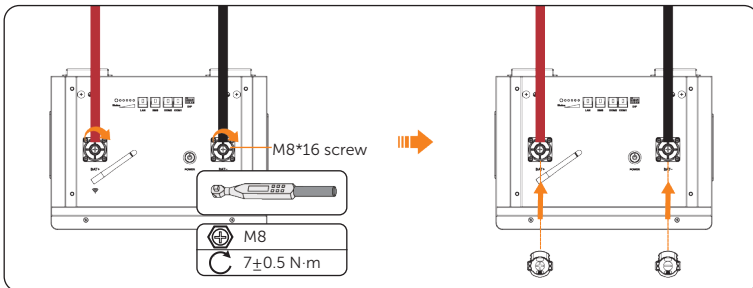

Figure 7-13 Securing power cables

### ⚠ WARNING!

- Screw the negative power cable first, then the positive power cable.

### NOTICE!

- For connection on the inverter side or on the parallel box side (if two or more battery packs are connected), please refer to the corresponding user manual.

# 8 Capacity and Power Expansion

## DANGER!

- Wear PPE and use insulated tools to avoid electric shocks or short circuits when increasing number of battery packs.

## NOTICE!

- For capacity or power expansion, you may have to dismantle the inverter or the battery. In that case, please strictly follow the corresponding user manual to remove or install.
- Please confirm that there is enough space to increase battery packs.
- Please make sure that the ground and wall where the additional battery packs will be installed can bear the weight.

## 8.1 Materials Requirements

The battery packs can be connected in parallel to realize capacity or power expansion by installing a parallel box. You need to prepare the parallel box and related materials based on your actual need.

### Requirements for copper bar of parallel box

The parallel box should at least consist of positive and negative copper bars suitable for the connection, which meet the following requirements:

- The recommended distance between the positive and negative copper bars is greater than 20 mm.
- The recommended distance between wiring holes on the copper bars is greater than 40 mm.
- The copper bars should comply to the local regulations. For example, to the capacity expansion with 6 battery packs, the recommended cross-sectional area for the copper bars is 250 (50\*5) mm<sup>2</sup>.

### Requirements for power cables

In addition to power cables included in accessories kit, you may need to provide additional power cables.

- Take the total currents into consideration. The allowable maximum discharge current of the battery is 250 A, the cross-sectional area of the power cables connecting on the battery side should be  $\geq 70$  mm<sup>2</sup>. Select the power cables connecting on the inverter side based on the current of the inverter.

- The recommended length of the positive and negative power cables is  $\leq 3$  m. The length of all power cables should be consistent.
- For the power cables connecting on the battery side, KST TLK70-8 terminals are recommended for crimping.
- If a circuit breaker is needed, its rated current should be  $\geq 250$  A.

## 8.2 Cable Connection

The system wiring diagram for capacity or power expansion is basically the same. Please install and connect the battery packs, inverter and parallel box as shown below.

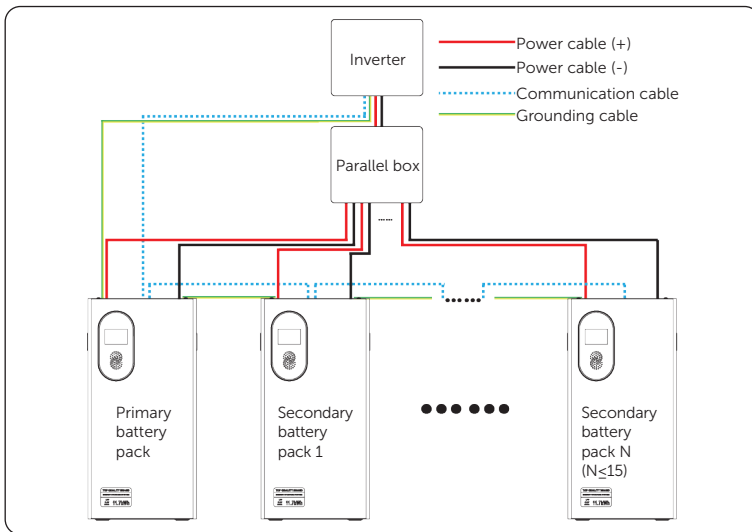

Figure 8-1 Wiring diagram for capacity expansion or power expansion

Regarding the cables shown in the Figure 8-1, see the following table.

Table 8-1 Cable connection information

Cable	Source	Description
Power cable (+)	Standard	<b>BAT+</b> port of battery pack to <b>BAT+</b> port of parallel box
Power cable (-)	Standard	<b>BAT-</b> port of battery pack to <b>BAT-</b> port of parallel box
Power cable (+)	Self-prepared	<b>BAT+</b> port of parallel box to <b>BAT+</b> port of inverter
Power cable (-)	Self-prepared	<b>BAT-</b> port of parallel box to <b>BAT-</b> port of inverter
Communication cable	Standard	<b>BMS</b> port of primary battery pack to <b>BMS</b> port of inverter
Communication cable	Standard	<b>COM2</b> port of battery pack to <b>COM1</b> port of next battery pack
Grounding cable	Self-prepared	⊕ port of primary battery pack to ⊕ port of inverter
Grounding cable	Self-prepared	⊕ port of battery pack to ⊕ port of next battery pack

NOTICE!

- If you want to increase a battery pack to the existing system to achieve capacity or power expansion, please make sure to shut down the system and disassemble cables as described in "12 Decommissioning".
- For the installation of the battery packs, please refer to "6 Mechanical Installation".

NOTICE!

- Please connect cables properly, and do not cross or wrap the cables together.
- For the specific wiring procedures, please refer to "7 Electrical Wiring".

### 8.3 DIP Switch Setting

To achieve capacity or power expansion successfully, the DIP switch should be correctly set:

- For power expansion,
  - » If you connect the system to SolaX inverter, keep the **DIP** switch of all battery packs as by default. You could set it via the inverter screen. For details, see the user manual of inverter.
  - » If you connect the system to the third-party inverter, keep the **DIP** switch 5 in **ON** position and flip the **DIP** switch 1–4 to **ON** position on the primary battery pack (the one connects to inverter). Keep the **DIP** switch of secondary battery packs as by default.
- For capacity expansion, keep the **DIP** switch of all battery packs as by default.

# 9 System Commissioning

## 9.1 Checking before Power-on

- Check whether the device is installed correctly and securely;
- All cables are connected correctly and securely;
- All unconnected port are covered;
- The installation space is proper, and the installation environment is clean and tidy.

### NOTICE!

- When power on or power off the system, please operate on the battery pack that connects with the inverter.



## 9.2 Power on the System

- Initial Startup refers to 1) powering on the system for the first time after receiving the package or 2) powering on the system for the first time after adding or removing battery packs in the system.
- Subsequent Power-on refers to powering on the system after it has been previously shut down.

### Initial startup

**Step 1:** Press and hold the **POWER** button for over five seconds and check the changes of the **Status** light, release the button when the **Status** light flashes yellow and wait for it to turn green.

Table 9-1 Description of Status light when initial startup

	Solid yellow	Flash yellow	Flash green
<b>Status</b> light			
	Start self test	End self test and Start address assignment	End address assignment and power on

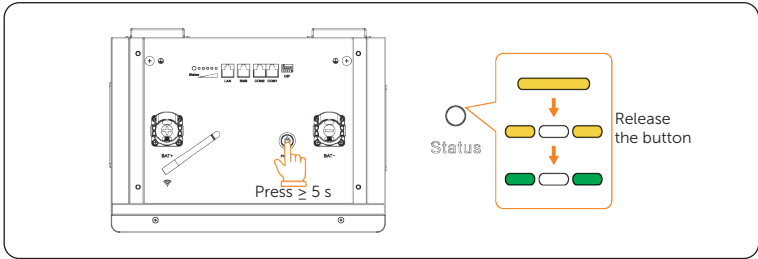

Figure 9-1 Initial startup

- Step 2:** (Only for third party inverters) Press the **POWER** button one more time to make sure the battery pack system could communicate with the third-party inverter normally.
- Step 3:** Adjust the antenna based on actual need (It is recommended to keep it vertical).

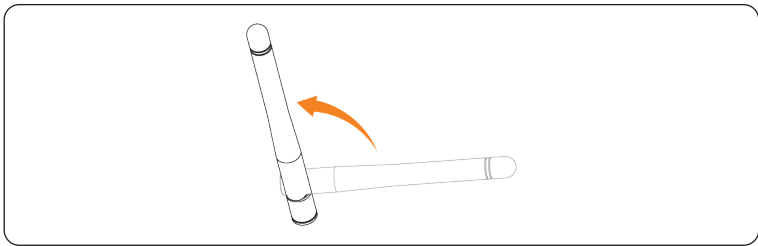

Figure 9-2 Adjusting the antenna

- Step 4:** Align the top cover (Part O) with the screw holes and the antenna of the battery pack, then secure it with the M5 screws (Part E).

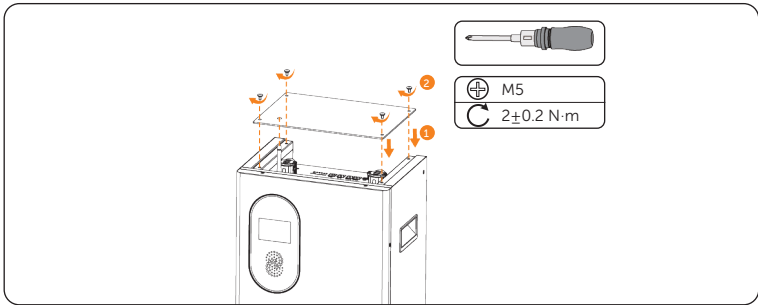

Figure 9-3 Install the top cover

## Subsequent power-on

- Step 1:** Unscrew the screws on the top cover counter-clockwise and remove the top cover.
- Step 2:** Press and hold the **POWER** button, then release the button when the **Status** light turns solid yellow. The **Status** light will turn to solid green 15 seconds later.

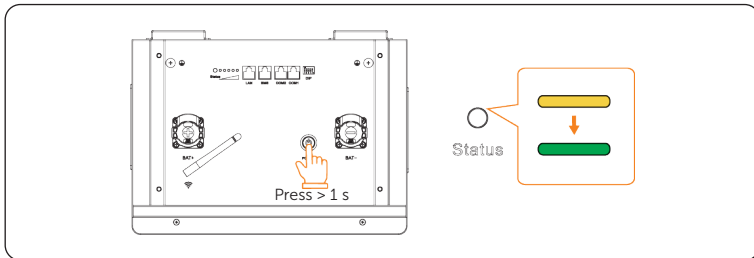

Figure 9-4 Subsequent startup

- Step 3:** (Only for third party inverters) Press the **POWER** button one more time to make sure the battery pack is normally powered on. The **Status** light will flash green every one second.
- Step 4:** Install the top cover back on the battery pack.

### NOTICE!

- For third-party inverters, the inverter should be included in *PYLON CANBUS Protocol* or *PYLON 485 Protocol* and you must press the **POWER** button once more to ensure the battery pack is successfully powered on.

## 9.3 Power off the System

Please follow the steps below to shut down the system.

- Step 1:** Please check that the inverter has been shut down.
- Step 2:** Unscrew the screws on the top cover counter-clockwise and remove the top cover.
- Step 3:** Press and hold the **POWER** button until the **Status** light comes on solid yellow. Then release the button and wait until the **Status** light and all SOC power indicators are off.
- Step 4:** Install the top cover back on the battery pack.

 **WARNING!**

- The device may still have power and heat after powering off, which may cause electric shock and personal injuries. Therefore, please allow it to cool for at least five minutes and wear PPE before conducting maintenance.

**NOTICE!**

- If you press the **POWER** button frequently, a system problem might occur. Hence, you should wait at least 10 seconds and then try again.

# 10 Operation on SolaX App and Web

---

## 10.1 Introduction of SolaXCloud

SolaXCloud is an intelligent management platform for home energy, which integrates energy efficiency monitoring, device management, data security communication and other integrated capabilities. While managing your home energy device, it helps you optimize the efficiency of electricity consumption and improve the revenue of power generation.

### NOTICE!

- You can scan the QR code on the performance label to check more device information. If the scan fails, you can manually input the SN number for checking.

## 10.2 Operation Guide on SolaXCloud App

### 10.2.1 Downloading and Installing App

Method 1: Scan the QR code below to download the App.

The QR codes are also available on the login page of our official website ([www.solaxcloud.com](http://www.solaxcloud.com)), and the installation guide of the dongle.



Figure 10-1 QR code

Method 2: Search for **SolaXCloud** in App Store or Google Play, and then download the App.

### 10.2.2 Operation on the SolaXCloud App

For instructions on related operations, create a new account and/or login to see the online documents (Click **Service** > **Help Center**) on the SolaXCloud App.

### 10.3 Operations on SolaXCloud Web Page

Open a browser and enter [www.solaxcloud.com](http://www.solaxcloud.com) to complete registration, login, add site and other related operations according to the guide.

# 11 Troubleshooting and Maintenance

## 11.1 Maintenance

Regular maintenance is required for the device. The table below lists the operational maintenance for expressing the optimum device performance. More frequent maintenance service is needed in the worse work environment. Please make records of the maintenance.

 **WARNING!**

- Only qualified person can perform the maintenance for the device.
- Wear PPE before conducting maintenance.

 **CAUTION!**

- The system must be powered off before conducting maintenance works, for instance, system cleaning, electrical connections, grounding cable checks.

Table 11-1 Maintenance list

Check Item	Description	Period
Running status of the system	<ul style="list-style-type: none"> <li>• Check whether there is any damage or deformation to the device.</li> <li>• Check whether there are any abnormal noise in the running system.</li> </ul>	Every 6 months
Electrical connections	<ul style="list-style-type: none"> <li>• Check whether the cables are fastened securely. If not, please tighten them again according to the torque written in the document.</li> <li>• Check whether there is any damage to the cables, especially the cable jacket connecting with the metal parts.</li> <li>• Check whether the unconnected ports are covered.</li> </ul>	The first maintenance should be scheduled within half a year after the first commissioning, and then check them every 6-12 months.
Grounding cable checks	<ul style="list-style-type: none"> <li>• Check whether the grounding cable is firmly attached.</li> </ul>	The first maintenance should be scheduled within half a year after the first commissioning, and then check them every 6-12 months.

## 11.2 Troubleshooting

This section lists the possible problems with the device, and provides information and procedures for identifying and resolving them. In case of any errors, users can:

- Check for the warnings or error messages on the LCD screen of the device;
- Log in the cloud platform ([www.solaxcloud.com](http://www.solaxcloud.com)) to check for the warnings or error messages, and then solve it according to the following table;
- Check for the warnings or error messages through the inverter.

For further assistance, contact SolaX Customer Service. Please provide the model and SN of the device, and be prepared to describe the system installation details.

Table 11-2 Troubleshooting information

Fault	Description	Diagnosis & Solution
Cell Overvoltage	Battery cell overvoltage fault	Battery cell overvoltage: <ul style="list-style-type: none"> <li>• Restart the battery.</li> <li>• Contact the after-sales personnel of our company.</li> </ul>
Cell Undervoltage	Battery cell undervoltage fault	Battery cell undervoltage: <ul style="list-style-type: none"> <li>• Make sure that the inverter is connected to the grid and that there is successful communication between the battery and inverter to ensure that the battery is charged.</li> <li>• Contact the after-sales personnel of our company.</li> </ul>
Hight Cell Vol Diff	The pressure difference between cells in the battery is too large.	The pressure difference between cells in the battery is too large: <ul style="list-style-type: none"> <li>• Restart the battery.</li> <li>• Contact the after-sales personnel of our company.</li> </ul>
HVB Overvoltage	Total voltage overvoltage fault	Total voltage overvoltage: <ul style="list-style-type: none"> <li>• Restart the battery.</li> <li>• Contact the after-sales personnel of our company.</li> </ul>
HVB Undervoltage	Total voltage undervoltage fault	Total voltage undervoltage: <ul style="list-style-type: none"> <li>• Make sure that the inverter is connected to the grid and that there is successful communication between the battery and inverter to ensure that the battery is charged.</li> <li>• Contact the after-sales personnel of our company.</li> </ul>

Fault	Description	Diagnosis & Solution
Main Relay Stuck (+)	Main positive relay contact adhesion	Relay contact adhesion: <ul style="list-style-type: none"> <li>Contact the after-sales personnel of our company.</li> </ul>
MOS Overtemp Fault	High temperature of MOS	The temperature of the MOS is too high: <ul style="list-style-type: none"> <li>Contact the after-sales personnel of our company.</li> </ul>
Main Relay Open (-)	Main negative relay fault	Relay fault: <ul style="list-style-type: none"> <li>Contact the after-sales personnel of our company.</li> </ul>
Precharge Fail	Precharge failure fault	Precharge failure fault: <ul style="list-style-type: none"> <li>Check the external connection and restart the battery.</li> <li>Contact the after-sales personnel of our company.</li> </ul>
Overtemp Fault	High temperature of the battery	The temperature of the battery is too high: <ul style="list-style-type: none"> <li>Stop battery charging or discharging and cool down the battery to normal temperature, and then restart it.</li> <li>Contact the after-sales personnel of our company.</li> </ul>
Self-check Fault	Self-check fault	Self-test fault: <ul style="list-style-type: none"> <li>Check other fault information and handle them, then restart the battery.</li> <li>Contact the after-sales personnel of our company.</li> </ul>
Temp Sample Fault	Temperature sampling anomaly	Temperature sampling anomaly: <ul style="list-style-type: none"> <li>Restart the battery.</li> <li>Contact the after-sales personnel of our company.</li> </ul>
Cell Sample Fault	Voltage sampling fault	Voltage sampling fault: <ul style="list-style-type: none"> <li>Restart the battery.</li> <li>Contact the after-sales personnel of our company.</li> </ul>
Insulation Fault	Insulation fault	Insulation fault: <ul style="list-style-type: none"> <li>Contact the after-sales personnel of our company.</li> </ul>
Dischrg Overcurrent	Discharge overcurrent of battery pack	Discharge overcurrent of battery pack: <ul style="list-style-type: none"> <li>Restart the battery.</li> <li>Check whether the loads matches the maximum power of the battery.</li> <li>Contact the after-sales personnel of our company.</li> </ul>

Fault	Description	Diagnosis & Solution
Chrg Overcurrent	Charge overcurrent of battery pack	Charge overcurrent of battery pack: <ul style="list-style-type: none"> <li>Restart the battery.</li> <li>Contact the after-sales personnel of our company.</li> </ul>
AFE Comm Fault	Internal communication fault	Internal communication loss: <ul style="list-style-type: none"> <li>Contact the after-sales personnel of our company.</li> </ul>
Mid Comm Fault	The communication between the primary and secondary battery packs is abnormal.	The communication between the primary and secondary battery packs is abnormal: <ul style="list-style-type: none"> <li>Check the communication connections and perform "black start".</li> <li>Contact the after-sales personnel of our company.</li> </ul>
Voltage Sensor Fault	Voltage sensor fault	Voltage sensor fault: <ul style="list-style-type: none"> <li>Restart the battery.</li> <li>Contact the after-sales personnel of our company.</li> </ul>
Low Temp Fault	Low temperature of the battery pack	The temperature of the battery is too low: <ul style="list-style-type: none"> <li>Wait for the battery to warm up to normal temperature, and then restart it.</li> <li>Contact the after-sales personnel of our company.</li> </ul>
Current Sensor Fault	Current sensor fault	Current sensor fault: <ul style="list-style-type: none"> <li>Contact the after-sales personnel of our company.</li> </ul>
PBOX Error	PBOX fault	PBOX fault: <ul style="list-style-type: none"> <li>Contact the after-sales personnel of our company.</li> </ul>
Flash Error	Flash fault	Flash fault: <ul style="list-style-type: none"> <li>Contact the after-sales personnel of our company.</li> </ul>
AFE Protect Fault	AFE self-protection failure	AFE self-protection failure: <ul style="list-style-type: none"> <li>Restart the battery.</li> <li>Contact the after-sales personnel of our company.</li> </ul>
Charge Request Fault	Charging request not responded	Inverter does not respond the charging request: <ul style="list-style-type: none"> <li>Restart the battery or the inverter.</li> <li>Charge the battery.</li> <li>Contact the after-sales personnel of our company.</li> </ul>

Fault	Description	Diagnosis & Solution
System Fault	Battery system fault	Battery system fault: <ul style="list-style-type: none"> <li>• Check other fault information and handle them, then restart the battery.</li> <li>• Contact the after-sales personnel of our company.</li> </ul>
Power Line Open	Power cables are not properly connected.	Improper connection of the power cables: <ul style="list-style-type: none"> <li>• Check and re-connect the power cables, then perform "black start".</li> <li>• Contact the after-sales personnel of our company.</li> </ul>
ID Duplicate	The battery packs with the same address number exist in the system.	The battery packs with the same address number exist in the system: <ul style="list-style-type: none"> <li>• Check the communication connections and perform "black start".</li> <li>• Contact the after-sales personnel of our company.</li> </ul>
WiFi Comm Fault	WiFi communication fault	WiFi communication fault: <ul style="list-style-type: none"> <li>• Check the WiFi signal.</li> <li>• Restart the battery.</li> <li>• Check on the LCD screen whether the WiFi connection is turned on.</li> <li>• Contact the after-sales personnel of our company.</li> </ul>
485 Comm Fault	RS485 communication fault	RS485 communication fault: <ul style="list-style-type: none"> <li>• Check and re-connect communication cables.</li> <li>• Contact the after-sales personnel of our company.</li> </ul>

# 12 Decommissioning

---

## 12.1 Disassembly of Cables

### WARNING!

- Only the qualified personnel can perform disassembly of cables.
- To avoid electric shocks, use insulated tools and wear individual protective tools when disassembly of cables.

### NOTICE!

- Take one battery pack for instance.

**Step 1:** Check that the inverter has been shut down.

**Step 2:** Unscrew the M5 screws on the top cover counter-clockwise, and take down the cover.

**Step 3:** Press and hold the **POWER** button until the **Status** light comes on solid yellow. Then wait until the **Status** light and all SOC power indicators are off.

**Step 4:** Make sure that the AC supply for inverter has been cut off.

**Step 5:** Remove the terminal caps and M8\*16 screws on **BAT+** and **BAT-** ports to unplug power cables.

**Step 6:** Unplug the communication cable(s) and reinstall the waterproof cap(s).

**Step 7:** Unscrew the M5 screw to disassemble the grounding cable.

## 12.2 Packing

- Load the battery pack into the original packing material if possible.
- If the original packing material is not available, you can also use the packing material which meets the following requirements:
  - » Suitable for the weight of product;
  - » Easy to carry;
  - » Be capable of being closed completely.

## 12.3 Disposing of the Rechargeable Battery

Properly dispose of the rechargeable battery or accessories in accordance with local regulations on the disposal of electronic waste.

# 13 Technical Data

<b>General</b>	
Battery model	TB-LD117
Battery type	LiFePO <sub>4</sub>
Scalability	Max. 16 pcs in parallel
Nominal voltage	51.2 d.c. V
Operating voltage range	42.4–57.6 d.c. V
Nominal energy	11.7 kWh
Usable energy (95% DOD) <sup>1</sup>	11.1 kWh
Rated power	5.8 kW
Max. power	12.8 kW
Peak output power	23.5 kW, 10 s
Recommend charge/discharge current	115 d.c. A
Max. charge/discharge current <sup>2</sup>	230 d.c. A/230 d.c. A
Depth of discharge	95%
Cycle life (95% DOD) <sup>3</sup>	> 6000 Cycles
Dimension (W x H x D)	355 mm x 726 mm x 263 mm
Net weight	88 kg
<b>Environmental requirements</b>	
Charge temperature	0°C to 55°C
Discharge temperature	-20°C to 55°C
Cooling concept	Natural cooling
Storage temperature	30°C to 60°C (6 months), -20°C to 30°C (12 months)
Relative humidity	5–95% RH
Max. operating altitude	3000 m
Installation type	Wall mounting / Floor mounting
Ingress protection	IP40
Environment	Indoor
<b>Communication interfaces</b>	
Display	Indicators/LCD
Communication interfaces	CAN2.0/RS485
<b>Standard</b>	
Hazardous materials classification	Class 9
Transport testing requirement	UN38.3
Protection class	I
Certification	IEC 62619, CE

**NOTICE!**

- <sup>1</sup> Test conditions: 95% DOD, 0.5C charge & discharge at 25°C. System usable energy may vary due to system configuration parameters.
- <sup>2</sup> The current is affected by the number of batteries connected in parallel as well as temperature and SOC. At the temperature of 25°C, the maximum discharge current can reach 250 d.c. A and last for 30 minutes.
- <sup>3</sup> Test conditions: 25°C ± 2°C, 0.5C charge & discharge, 70% EOL.



## **SolaX Power Network Technology (Zhejiang) Co., Ltd.**

Add.: No. 278, Shizhu Road, Chengnan Sub-district, Tonglu County,  
Hangzhou, Zhejiang, China  
E-mail: [info@solaxpower.com](mailto:info@solaxpower.com)