

BY SOLAX

TRIPLE
POWER



TSYS-HR76

User Manual

Version 1.0

www.solaxpower.com



STATEMENT

Copyright

Copyright © SolaX Power Network Technology (Zhejiang) Co., Ltd. All rights reserved.

No part of this manual may be reproduced, transmitted, transcribed, stored in a retrieval system, or translated into any language or computer language, in any form or by any means without the prior written permission of SolaX Power Network Technology (Zhejiang) Co., Ltd.

Trademarks



POWER and other symbol or design (brand name, logo) that distinguishes the products or services offered by SolaX has been trademark protected. Any unauthorized use of above stated trademark may infringe the trademark right.

Notice

All or part(s) of the products, features and services described in this document may not be within your scope of purchase or usage. Unless otherwise specified in the contract, the contents, information and recommendations in this document are provided as is, SolaX makes no kind of warranties, guarantees or representations expressly or implicitly.

The content of the documents is continually reviewed and amended, where necessary. However, discrepancies cannot be excluded. SolaX reserves the right to make improvements or changes in the product(s) and the program(s) described in this manual at any time without the prior notice.

The images contained in this document are for illustrative purposes only and may vary depending on product models.

Please visit the website www.solaxpower.com of SolaX Power Technology (Zhejiang) Co., Ltd. for more information.

SolaX reserves all the right for the final explanation.

About This Manual

Scope of Validity

This manual is an integral part of TSYS-HR76. It describes the transportation, storage, installation, electrical connection, commissioning, maintenance and troubleshooting of the product. Please read it carefully before operating.

Model Code

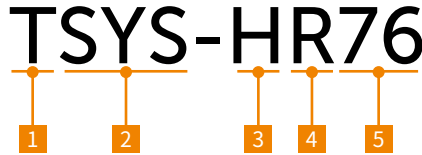

No.	Code	Description
1	T	Product type: Triple Power
2	SYS	Battery system
3	H	Grid grade: High-voltage system
4	R	Rack mounted
5	76	Battery capacity: 7.6 kWh



Target Group

The installation and maintenance can only be performed by qualified personnel who:

- Are licensed and/or satisfy state and local jurisdiction regulations;
- Have good knowledge of this manual and other related documents.

Conventions

The symbols that may be found in this manual are defined as follows.

Symbol	Description
 DANGER	Indicates a hazardous situation which, if not avoided, will result in death or serious injury.
 WARNING	Indicates a hazardous situation which, if not avoided, could result in death or serious injury.
 CAUTION	Indicates a hazardous situation which, if not avoided, could result in minor or moderate injury.
NOTICE!	Provides tips for the optimal operation of the product.

Change History

Version 1.0 (2025-11-24)

Corrected Fig. 2-1.

Deleted document material number QR code and contact information.

Updated "5.2 Scope of Delivery" (Deleted document from the battery pack kit).

Version 0.0 (2025-8-30)

Initial release

Table of Content

- 1 Safety..... 1
 - 1.1 General Safety.....1
 - 1.2 Battery Safety.....2
 - 1.3 Electrical Safety.....5
- 2 Product Overview..... 8
 - 2.1 Product Introduction..... 8
 - 2.2 Product Appearance 9
 - 2.2.1 Product Dimensions and Weight..... 9
 - 2.2.2 Parts Introduction.....11
 - 2.3 Black Start.....15
 - 2.4 Label.....16
 - 2.5 Explanation of Symbols and Icons.....17
- 3 Transportation and Storage 18
 - 3.1 Transportation Requirements.....18
 - 3.2 Storage Requirements19
- 4 Preparation before Installation20
 - 4.1 Selection of Installation Location.....20
 - 4.1.1 Installation Environment Requirements.....21
 - 4.1.2 Installation Carrier Requirement22
 - 4.2 Tools Requirement.....25
 - 4.3 Additionally Required Materials.....25
- 5 Unpacking and Inspection.....26
 - 5.1 Unpacking26
 - 5.2 Scope of Delivery.....27
- 6 Installation and Wiring for Single-Rack Battery System30
 - 6.1 Installation for Single-Rack Battery System31
 - 6.2 Wiring for Single-Rack Battery System.....38
 - 6.2.1 PE Connection39
 - 6.2.2 Communication Cable Connection.....41
 - 6.2.3 Power cable connection.....43
 - 6.2.4 Connection to Inverter.....46
- 7 Installation and Wiring for Dual-Rack Battery System.....50

7.1	Installation for Dual-Rack Battery System	52
7.2	Wiring for Dual-Rack Battery System	59
7.2.1	PE Connection	60
7.2.2	Communication Cable Connection	62
7.2.3	Power cable connection	64
7.2.4	Connection to Inverter.....	68
8	System Commissioning.....	72
8.1	Checking before Powering On	72
8.2	Power On.....	72
9	Capacity Expansion.....	75
9.1	Adding Battery Packs.....	75
9.2	Connecting Two Battery Towers to Inverter in Parallel	79
10	Troubleshooting and Maintenance	81
10.1	Maintenance	81
10.2	Troubleshooting	82
11	Decommissioning.....	85
11.1	Disassembly of Cables.....	85
11.2	Packing.....	88
12	Technical Data.....	89

1 Safety

1.1 General Safety

Before transporting, storing, installing, operating, using and/or maintaining the device, please carefully read and understand the document, and strictly follow the instructions and safety precautions given herein, as well as symbols affixed on the device. The safety instructions herein are only supplements to local laws and regulations.

The operator should not only abide by all safety precautions provided in the document, including but not limited to the "Danger" sign, "Warning" sign, "Caution" sign, and "Notice" sign, but also comply with relevant international, national and local laws, regulations, standards, guidelines and industry rules in the process of transportation, storage, installation, operation, and maintenance. SolaX will not assume any responsibilities for the loss caused by improper operation, or violation of safety standards for design, production and equipment suitability.

SolaX will not be liable for maintenance for possible device failure, device malfunction, or parts damage, nor will the company assume any liability to pay compensation for the possible physical and property damage resulting from the installation environment that does not meet the design requirements.

The device is well designed and tested to meet all applicable state and international safety standards. However, like all electrical and electronic equipment, safety precautions must be observed and followed during the installation of the device to reduce the risk of personal injury and to ensure a safe installation.

SolaX will not assume any responsibilities if any of the following circumstances occur, including but not limited to:

- Device damage due to force majeure, such as earthquake, flooding, thunderstorm, lighting, fire hazard, volcanic eruption, war, typhoon, tornado, etc.
- Device damage due to human causes.
- Device used or operated against local policy or regulations.
- Failure to follow the operation instructions and safety precautions on the product and in this document.
- Installation and use under improper environment or electrical condition.
- Unauthorized modifications to the product or software.
- Device damage caused during transportation by the customer or the third party.
- Battery damage caused by strong vibrations from external factors before, during and after installation.
- Storage conditions that do not meet the requirements specified in this document.
- Use of incompatible inverters or devices.
- Installation and commissioning operated by unauthorized personnel who are not licensed and /or satisfy state and local jurisdiction regulations.

1.2 Battery Safety

DANGER!

- Do not connect the positive and negative poles of a battery together. Otherwise, it may be short-circuited. This will result in an excessive flow of current and large quantities of energy for a short time, and then will cause battery leakage, smoke, the emission of flammable gases, thermal runaway, fire, or even an explosion. Therefore, the battery must be powered off before maintenance.
- If a battery is overheated, it will cause leakage, smoke, release of flammable gases, thermal runaway, fire, or even an explosion. Therefore, Ensure that the installation site shall be well ventilated and kept away from high temperatures.
- Do not dismantle, change, shake, drop, crush, impact, cut, penetrate with a sharp object, or any other ways to damage the battery. Otherwise, it may cause leakage, smoke, emission of flammable gases, thermal runaway, fire, or even an explosion.
- Do not mix different types or makes of the battery. Otherwise, it may cause leakage or rupture, resulting in personal injury or property damage.
- The battery electrolyte is toxic and volatile. Never get in contact with the leaked liquids or inhale gases in the case of the battery leakage or odor, and contact professionals immediately. The professional must wear PPE (including but not limited to safety glasses, safety gloves, gas masks, and protective clothing) before powering off the device, and then contact our company at once after removing the damaged battery.
- Normally, the battery will not release any gases. However, in the following situations: burnt, needle-pricked, squeezed, struck by lightning, overcharged, or subject to other adverse conditions that may cause battery thermal runaway, the battery may be damaged or an abnormal chemical reaction may occur inside the battery, resulting in electrolyte leakage or production of gases. If the battery needs to exhaust flammable gas, safe emission measures must be taken to prevent fire and device corrosion.
- Do not use damaged batteries.

WARNING!

- Please read the document carefully before installation, operation and maintenance.
- Must arrange fire-fighting equipment in advance according to the local laws, regulations, and standards while installing and commissioning the device.
- Please check that there is no damage to the outer packaging before and after unpacking, and in the process of storage and transportation. The battery shall be correctly placed or stacked in accordance with the requirements stipulated on the labels to prevent damaging or scrapping the battery resulting from crushing or falling.
- Must tighten screws securing cables and on the copper bars according to the torque information specified in the document, and check whether they are tightened periodically. For instance, whether there is any rust, corrosion, or any other foreign object on it, and then clean it up if any. Because the loose screw connections may result in excessive voltage drops and large currents, leading to generating a lot of heat and burning the battery.

 **WARNING!**

- The battery should be charged in time after discharge, to prevent battery damage due to overdischarge. If a battery pack is stored for a long time, please periodically recharge it to protect it from damage according to the storage requirements specified in the document.
- Please charge the battery within the specific temperature range because the low temperature may result in a short circuit. Hence, do not charge it when the temperature is below the low limit of the operating temperature.
- Do not use the battery when you find a bulge, or dents on the battery housing, and contact the installer or professional maintenance personnel to dismantle and replace it. The damaged battery must be kept away from other devices and flammable and explosive articles, and do not contact it except for professionals.
- Before operation, ensure that there are no irritating or burning smells around the battery.
- Do not weld or grind near a battery. Because electric sparks or arcs may cause fires.
- Do not step, lead, stand, or set on the battery.

 **CAUTION!**

- The IP20 ingress protection requires the device to be installed indoors. Exposure to direct sunlight or rain is prohibited.

NOTICE!**Transportation requirements for battery:**

- Relevant qualifications for the transport of dangerous goods must be obtained by the forwarding agent engaged in such businesses, and they must strictly abide by the local regulations for the transport of dangerous goods.
- Please check the battery before transportation. If a battery leaks, smells, or is damaged, do refuse to transport it.
- Please handle gently in the process of loading and unloading, transportation, and moving a battery to prevent bumping, and take effective moisture-proof measures to prevent personal injuries and battery damage.
- Unless otherwise specified, do not transport the batteries, which are classified as dangerous goods, together with food, medicine, or other additives on the same means of transport.

NOTICE!

If the battery leaks electrolyte or any other chemical materials, the electrolyte leakage can lead to toxic gases. Therefore, do not contact with them at all times. In case of accidentally coming into contact with them, please do as follows:

- In case of inhalation: Leave the contaminated area immediately, and seek medical attention at once;
- In case of contact with eyes: Rinse eyes with running water for at least 15 minutes, and seek medical attention;
- In case of contact with skin: Wash the contact area thoroughly with soap, and seek medical attention;
- In case of ingestion: Induce vomiting, and seek medical attention.

If a fire breaks out where the battery is installed, please do as follows:

- In case a battery is charging when the fire breaks out, provided it is safe to do so, press the emergency stop button and unplug the power cable;
- In case a battery is not on fire yet, use a water-based fire extinguisher or a carbon dioxide extinguisher to extinguish the fire;
- In case a battery catches fire, do not try to put it out, and evacuate immediately;

Recovery of damaged or wasted battery:

- Dispose of the damaged or wasted batteries according to local laws and regulations instead of placing them in the household trash or curbside recycling bins. Otherwise, it may cause environmental pollution or explosions.
- Ensure that the damaged or wasted batteries are not exposed to the following situations: high temperatures, high humidity, direct sunlight, or corrosive environments.
- Contact a battery recycling company to scrap the battery, which leaks electrolytes, or is damaged or expired.
- Please take protective steps to prevent battery short circuits before moving batteries.
- Please keep away from flammable material storage areas, residential areas, and other population centres when transporting and storing the damaged battery.

1.3 Electrical Safety

DANGER!

- Please make sure that the unit is free from any damage before the electrical connection.
- Do not modify, change, or dismantle the device.
- Do not change the power-on and power-off sequences and the installation procedure written in the document, and please properly and correctly operate it.
- Do not power on the device during installation. Otherwise, it may cause a fire, personal injury, or device damage.
- Must remove earrings, rings, bracelets, watches, and any other metal jewelry before operation, to avoid electrical shock, burns, or even death.
- During operation, special insulated tools must be used to avoid electric shock or short circuit failure. The insulated tools' voltage ratings must exceed the system voltage ratings. Please see "12 Technical Data" for system information.

WARNING!

- Please wear PPE, such as, protective clothing, insulating shoes, goggles, safety helmets, insulating gloves, etc., when conducting electrical wiring.
- Please check that there is no damage to the outer packaging before unpacking. If damaged, do not use and contact the transporter and manufacturer immediately.
- Do not place installation tools, metal parts and other sundries on the battery while installing. Items on and around it need to be cleaned up in time after finishing installation.
- Do not install the battery in rain, snow, fog and other weather to avoid battery damage.
- If the battery is damaged or accidentally drenched in water, do not install and use it. Please transport it to a safety isolation point and contact the local fire department or professional technicians for scrapping.
- If the battery cables are submerged in water, do not approach, touch or use them.
- Ensure that the positive and negative terminals of the battery are not accidentally grounded. If accidental grounding occurs, disconnect the battery terminals from the ground immediately.
- Do not touch the power supply equipment directly, or through conductors or damp objects.
- Do not touch the parts of the equipment of which warning signs are attached, to avoid personal injury or device damage.

CAUTION!

- Do not power on the device until it has been installed and confirmed by professionals.
- In the event of a fire, evacuate immediately and call the local fire services.

NOTICE!

General requirement:

- Please operate according to the safety code for power station.
- Please make sure that the equipment and its associated switches are off before connecting and disconnecting power cables.
- Please check whether the protective housing and insulating sleeve for an electrical component have been installed correctly after finishing installation, to avoid electric shock.
- Must turn off the output switch of the power supply equipment when maintaining its electrical terminal device and power distribution device.
- If the device is required to be powered off during troubleshooting and diagnosis, please do as the following procedure: power off > electricity testing > connecting PE cable > hanging warning signs and setting up guardrails.
- Must hang up "Do Not Switch On" warning signs on the relevant switches or circuit breakers before completing maintenance, to prevent power connection. Do not switch on before the fault is solved.
- Do not use water, alcohol, oil, or other solvents when cleaning electrical components inside and outside the device.

Grounding requirement:

- The device's grounding impedance shall meet the requirements of local electrical safety standards.
- The equipment shall be permanently connected to a grounding wire within the building's electrical system. Please check whether the device is reliably grounded before operation. The PE cable should be removed last while dismantling and maintaining the device.
- Do not start the device if it is not fitted with a grounding conductor.
- All acts against the grounding conductor are prohibited.
- If the device is equipped with a three-pronged socket, make sure that the ground prong is reliably grounded.
- For the device that may generate large contact currents, please make sure that the grounding terminal on the housing has been grounded before powering on, to avoid electric shock.

Cable requirement:

- When deciding the wire diameter, and connecting or wiring cables, follow the local laws, regulations, and codes to ensure safety.
- Before connecting power cables, please make sure that the cable labels are correctly labelled and the cable terminals are well insulated.
- Do not loop and twist cables while conducting electrical wiring. If the length of the power cable is not enough, please replace it instead of joining or welding. Ensure that all the cables of the correct type and size are fully connected and well insulated, and the edges of cable slots and crossing holes are smooth.
- Cables should be kept away from heaters or other heat sources, because a high temperature environment may result in aging and damage to cable insulation.

NOTICE!**Short circuit protection:**

- Please use electrical tape to wrap the bare conductor cables to prevent short circuits when installing and maintaining the battery.
- Prevent any object from entering into batteries, which may cause a short circuit.
- Regularly check the screws or copper bars on the device, to ensure that they are fully tightened.

2 Product Overview

2.1 Product Introduction

Characterized by easy installation, high reliability, high safety, intelligent management, and flexible configuration, TSYS-HR76 is a rack energy storage battery system designed for SolaX inverters. It consists of a high-voltage box, battery packs, and a battery rack (with protective cover):

- **High-voltage box:** Plays the role of brain in the whole battery system. It manages battery packs intelligently by monitoring their status.
- **Battery pack:** Stores or supplies electrical power under the command of high-voltage box.
- **Battery rack:** Supports the high-voltage box and battery packs.

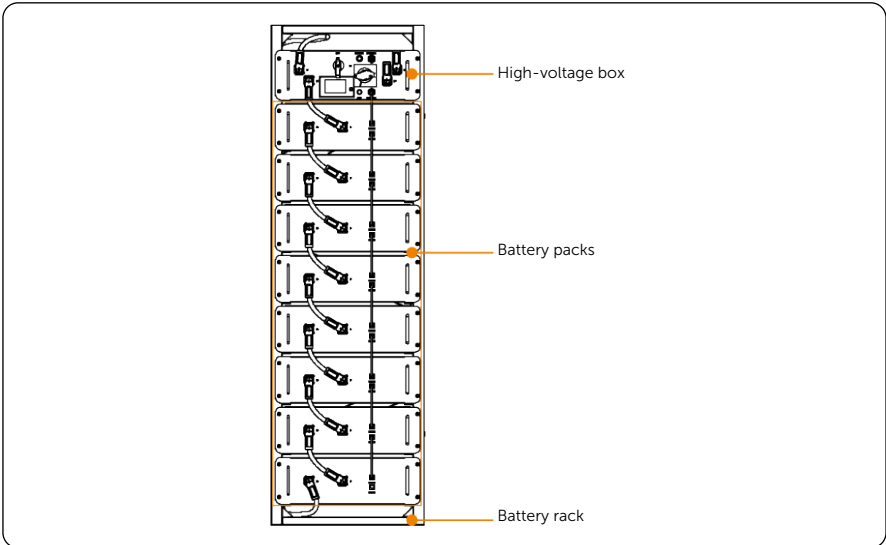

Figure 2-1 TSYS-HR76

2.2 Product Appearance

2.2.1 Product Dimensions and Weight

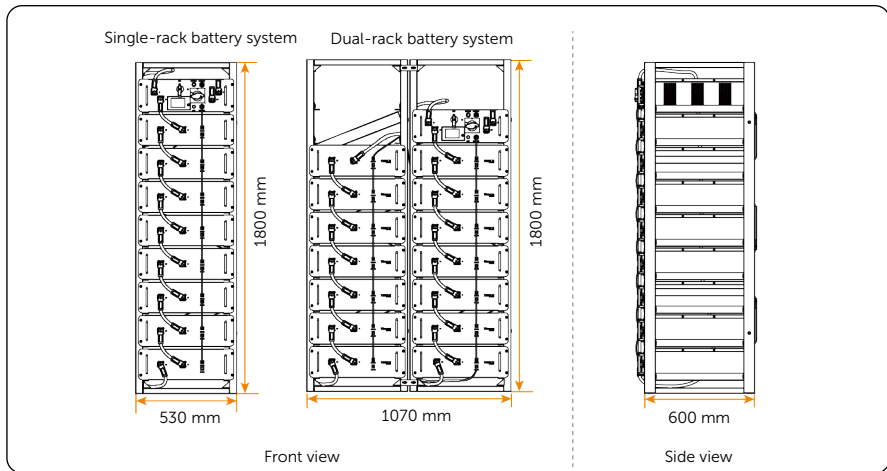

Figure 2-1 Battery system

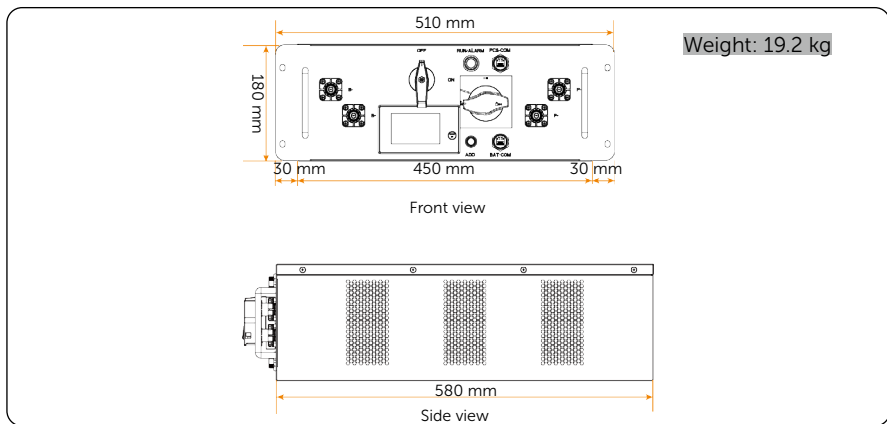

Figure 2-1 High-voltage box

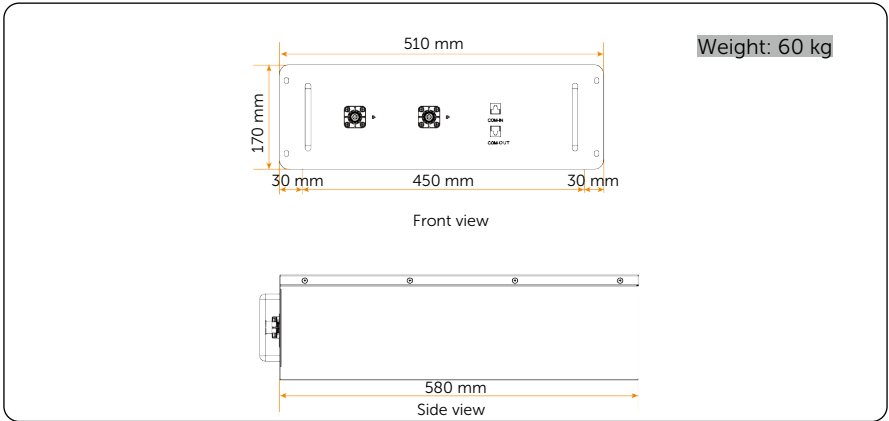

Figure 2-2 Battery pack

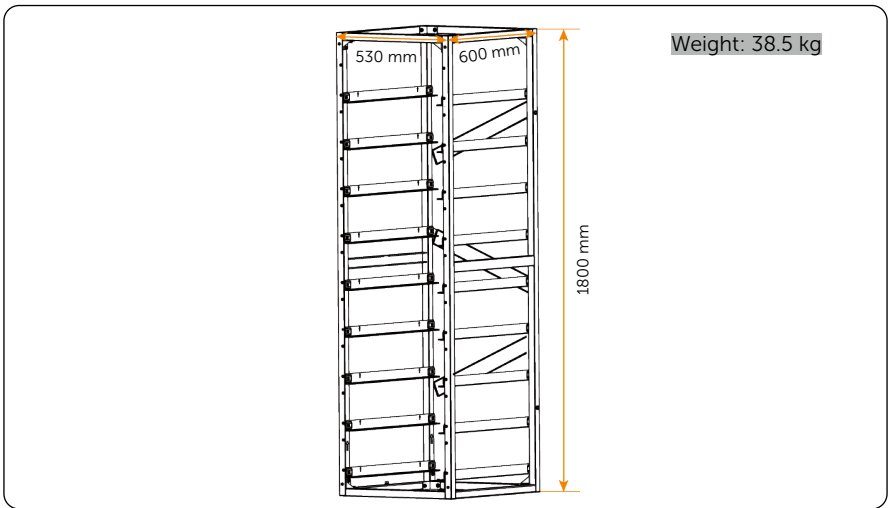

Figure 2-3 Battery rack

2.2.2 Parts Introduction

High-voltage box

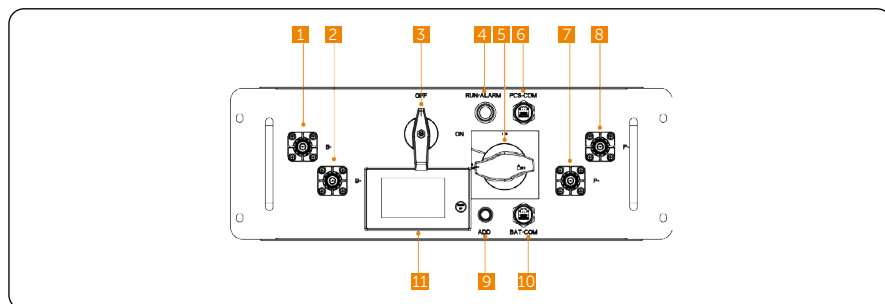

Figure 2-4 High-voltage box

Table 2-1 Description of high-voltage box

SN	Name	Description
1	Port B-	Used to connect to port B- of a battery pack.
2	Port B+	Used to connect to port B+ of a battery pack.
3	Auxiliary power Switch	To switch on/off the battery system.
4	Indicator RUN/ALARM	Displays the running status and upgrade progress of the whole battery system. For details, see "Table 2-2 Description of indicator RUN/ALARM" .
5	Battery switch	Used to establish or cut off a power connection with an inverter.
6	Port PCS-COM	Used to connect to port BMS1 or BMS2 of an inverter (X3-AELIO as example).
7	Port P+	Used to connect to port BAT+ of an inverter (X3-AELIO as example).
8	Port P-	Used to connect to port BAT- of an inverter (X3-AELIO as example).
9	Key ADD	Used to initiate address assignment or black start. For details, see "Table 2-3 Functions of key ADD" .
10	Port BAT-COM	Used to connect to port COM-IN of a battery back.
11	Display screen	Used to display the basic data of a battery tower. For details, see "STATEMENT" .

Table 2-2 Description of indicator **RUN/ALARM**







Indicator	Battery system status
	Solid green In standby state & running normally
	Flashes green for 2s every 0.85s In discharge mode
	Flashes green for 0.85s every 0.85s In charge mode
	Flashes green for 0.1s every 0.1s Assigning communication addresses
	Solid red Alarming
	Flashes green and red alternatively Upgrading

Table 2-3 Functions of key **ADD**

Function	Operation
Address assignment	Long press the ADD key for more than 10s until the RUN/ALARM indicator flashes green fast. When it stops flashing, it indicates that address assignment succeeds.
Black start	Press the ADD key three times consecutively and quickly. At this time, if the RUN/ALARM indicator turns from "solid green" into "slow flash green", it indicates that black start succeeds. For details, see "2.3 Black Start" .

Display screen

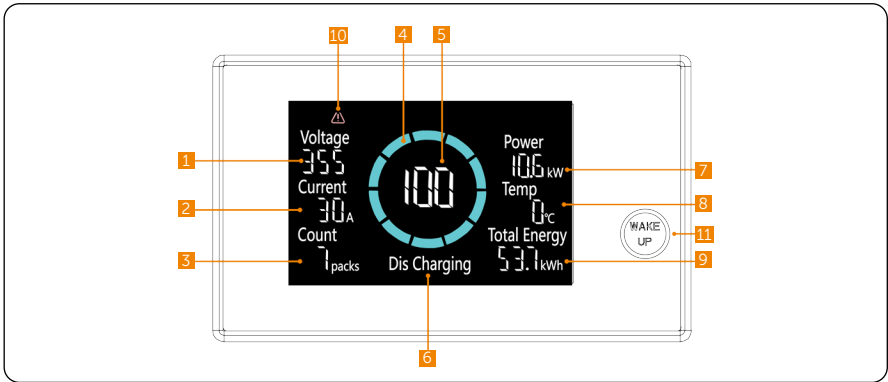

Figure 2-5 Display screen in the high-voltage box

Table 2-4 Description of display screen

SN	Name	Description
1	Voltage display area	Displays the total voltage of the current battery tower.
2	Current display area	Displays the current of the current battery tower.
3	Pack quantity display area	Displays the number of battery packs in the battery tower.
4	SOC display area	It is divided into 10 parts equally. Each part represents 10% of the total SOC.
5	SOC or fault code display area	<ul style="list-style-type: none"> When no fault occurs to the battery, it displays the specific value of SOC. When a fault occurs to the battery, it displays the fault code. If multiple faults occur to the battery tower simultaneously, it will display multiple fault codes alternatively every 5s.
6	Battery work state display area	<ul style="list-style-type: none"> If the battery is being charged, it displays Charging. If the battery is discharging, it displays DisCharging. If the battery neither charges nor discharges, it displays nothing.
7	Real-time power display area	Displays the real-time power of the current battery tower.
8	Temperature display area	Displays the temperature of the current battery tower.
9	Total energy display area	Displays the total energy of the current battery tower.
10	Warning sign	When a fault occurs to the battery tower, it lights up. If the fault is solved, it will light out.
11	Key WAKE UP	If the screen falls asleep, press the key to wake it up.

Battery pack

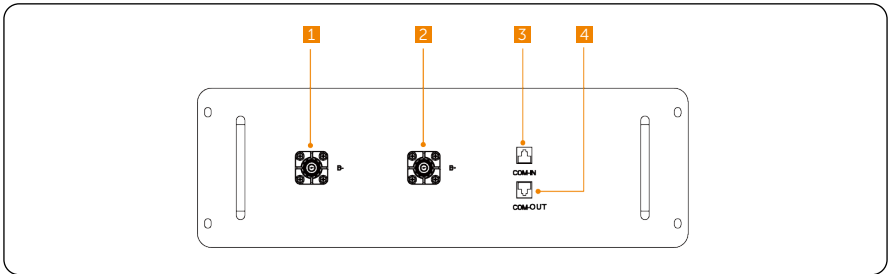

Figure 2-6 Battery pack

Table 2-5 Description of battery pack

SN	Name	Description
1	Port B-	Used to connect to port B- of a high-voltage box or battery pack via a power cable.
2	Port B+	Used to connect to port B+ of a high-voltage box or battery pack via a power cable.
3	Port COM-IN	Used to connect to a high-voltage box or battery pack via a communication cable.
4	Port COM-OUT	Used to connect to a battery pack via a communication cable or connect a terminating resistor.

Battery rack

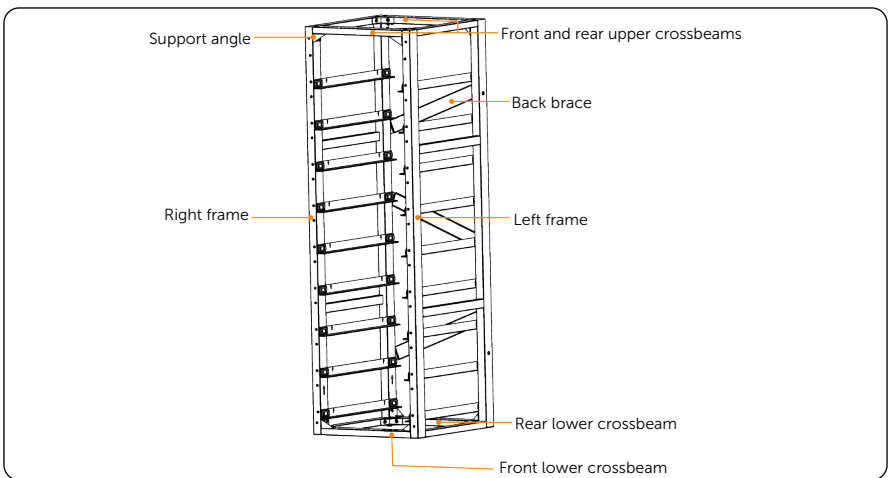

Figure 2-7 Composition of battery rack

2.3 Black Start

Black start is to ensure the battery's consistent power supply to an inverter when the Grid and PV are both unavailable to the inverter.

To enable black start, follow steps below:

Step 1: Turn off the high-voltage box and then restart it instantly.

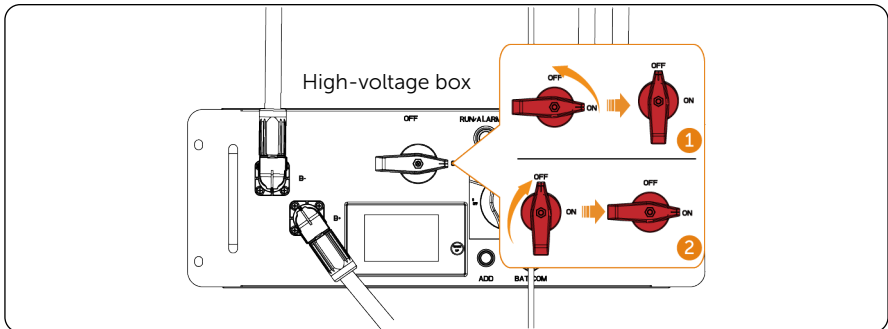

Figure 2-8 Turn off the high-voltage box and restart it

Step 2: Press the **ADD** key three times quickly and consecutively. At this time, if the **RUN/ALARM** indicator turns from "solid green" into "slow flash green", it indicates that black start succeeds.

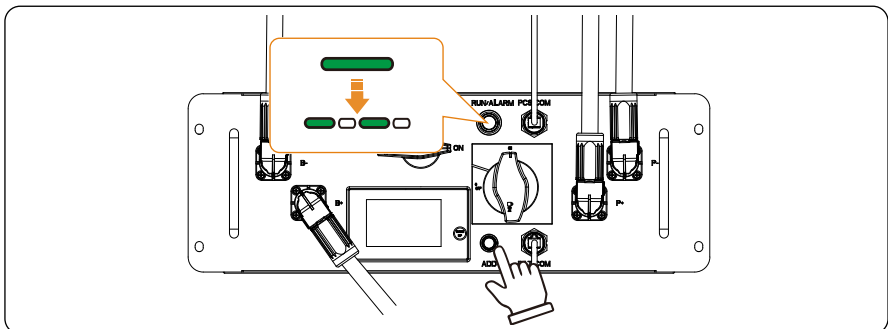

Figure 2-9 Press **ADD** key three times fast

NOTICE!

- Do not press the **ADD** key too long! The duration of your finger staying on the key each time must be less than 10s. Otherwise, the battery will automatically assign communication addresses.
- The interval between two key pressing must be less than 2s. Otherwise, the operation will be invalid! And you have to the press the key three times again!

2.4 Label

Labels, such as performance label and manufacture label shall be pasted onto the battery pack and high-voltage box. They are located at the front or top of the battery pack and high-voltage box. The system performance label and startup label are shown below:

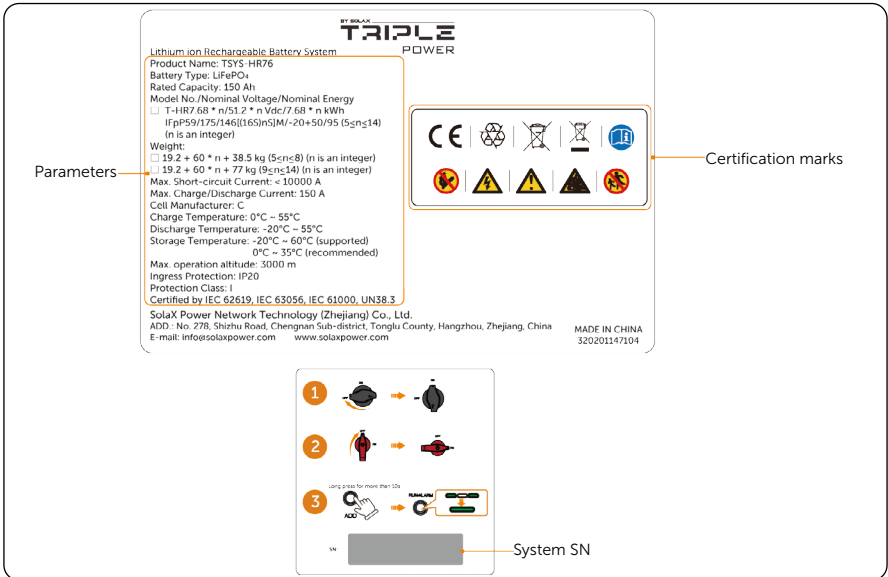

Figure 2-1 System performance label and startup label

SN is encoded according to the 32-base numeral system. It is used to identify the battery type, specific features, manufacture date, order serial number, and factory serial number.

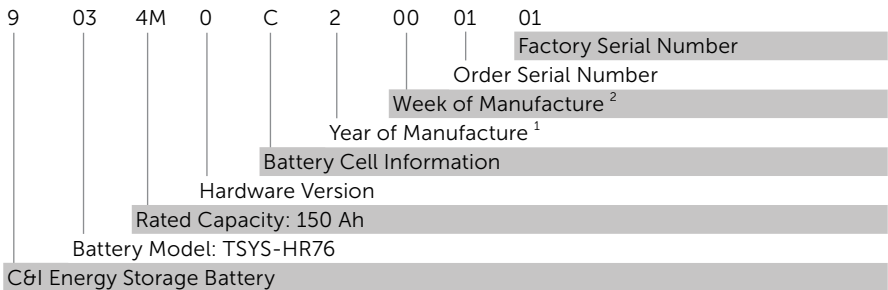









Figure 2-2 Explanation of SN

1 "2023~2032" is represented by "0-9", "2033~2058" is represented by "A-Z" ...
 2 The two digits represent in which week the battery pack was produced. There are totalling 52 weeks in a year, and the first week is represented by 00, and the second week is represented by 01. The others are coded in the same way.

2.5 Explanation of Symbols and Icons

The meaning of the symbols and icons on the labels is shown as follows:

Table 2-1 Explanation of symbols and icons

Symbol and Icon	Description
	CE mark of conformity.
	Protective grounding point.
	The battery module may explode. The rechargeable battery can become hot during operation. Avoid touch during operation.
	Danger, electric shock. Do not touch the device after it is powered on. Otherwise, an electric shock may occur.
	Danger. Due to possible risks, do not touch the device after it is powered on.
	Observe enclosed documentation.
	The device cannot be disposed together with the household waste.
	The device cannot be disposed together with the household waste.
	The battery system must be disposed of at a proper facility for environmentally-safe recycling.
	Keep the device away from children.
	Keep the device from open flames or ignition sources.

3 Transportation and Storage

3.1 Transportation Requirements

DANGER!

- Be careful to avoid physical collisions during transportation. Do not place the equipment upside down and do not expose the equipment to water, which may result in equipment damage, fire disaster or explosion.

CAUTION!

- The high-voltage box, battery pack, and battery rack must be transported in its original packaging. SolaX will not be held responsible for any damage to the high-voltage box, battery pack, and battery rack caused by improper transportation or by transportation after it has been installed.
- Please strictly comply with the transportation requirements of the warning signs on the packaging and equipment.
- Relevant qualifications for the transport of dangerous goods must be obtained by the forwarding agent engaged in such businesses, and they must strictly abide by the local regulations for the transport of dangerous goods. Please check the battery before transportation. If a battery leaks, smells, or is damaged, do refuse to transport it.

NOTICE!

- Please choose an appropriate transport method based on site conditions and device weight.
- Please wear PPE (e.g. protective gloves, shoes, belt, etc.) and lift the device with proper postures, to prevent personal injuries and device damage.
- Please reasonably arrange the number of workers, the right mix, and the handling position to achieve distributing weight and balancing load when moving the device.
- Please hold the handles or the bottom of the device when moving, to avoid device damage.
- Please pay attention to the surrounding environment when moving, such as obstacles and slippery ground, to avoid personal injuries and device damage.

3.2 Storage Requirements

 **DANGER!**

- The battery must be stored indoors, which should meet the following requirements:
 - » Avoid exposure to direct sunlight or rain.
 - » Keep dry and well-ventilated.
 - » Keep away from heat, fire sources, radiation, chemicals, dust or metal conductive dust.
 - » Be equipped with fire facilities.
- Batteries must be stored in accordance with the requirements of warning signs and other information on the packaging.
- Do not store with any other electronic equipment, chemicals, or other items that may cause interference or danger.
- Pay attention to the height when stacking batteries to avoid deforming or damaging the battery.

NOTICE!

- Store the device according to the signs on the packaging.
- Do not store the batteries for a long time. If long periods of storage are unavoidable, please recharge it periodically to avoid battery damage.
- If the battery has been stored for more than 1 year, it must be checked and tested by professionals before use.
- The relative humidity should be between 5% and 85%.
- It is recommended to store the battery in a temperature range of 0°C to +35°C.

Table 3-1 Storage temperature and recharge frequency

Storage temperature	Recharge frequency
+50°C to +60°C	Once every 3 months
+35°C to +50°C	Once every 6 months
-20°C to +35°C	Once every 12 months

4 Preparation before Installation

4.1 Selection of Installation Location

NOTICE!

- Since the operating temperature affects the operation and service life of a battery, please install it in an appropriate ambient environment.
- The operating ambient temperature for the battery is between -20°C and $+55^{\circ}\text{C}$.

The installation location selected for the rechargeable battery is quite critical in the aspect of the guarantee of machine safety, service life and performance.

- The selection of installation sites must strictly comply with local laws, regulations, and related industry standards;
- Fire extinguishers must be configured at the installation site according to the local fire codes;
- Flaunting an IP20 enclosure, the battery can only be used indoors.
- The installation site shall be convenient for wiring connection, operation and maintenance;
- During the planning phase, reserve enough space for capacity expansion or others in the future;
- Good transportation for the installation site;
- Do not install devices on the undesirable floor that are prone to deformation and settlement;
- Keep away from salt-damaged areas, sand and dust areas, or polluted areas, or the device will corrode.

4.1.1 Installation Environment Requirements

Make sure the installation site meets the following conditions:

- Ambient temperature: $-20^{\circ}\text{C}\sim+55^{\circ}\text{C}$;
- Relative humidity: 5~85% RH
- Altitude: Below 3000 meters;
- Keep good ventilation;
- Keep away from combustibles, inflammable and explosive materials, antenna and corrosive substances.

Figure 4-1 Environment requirements

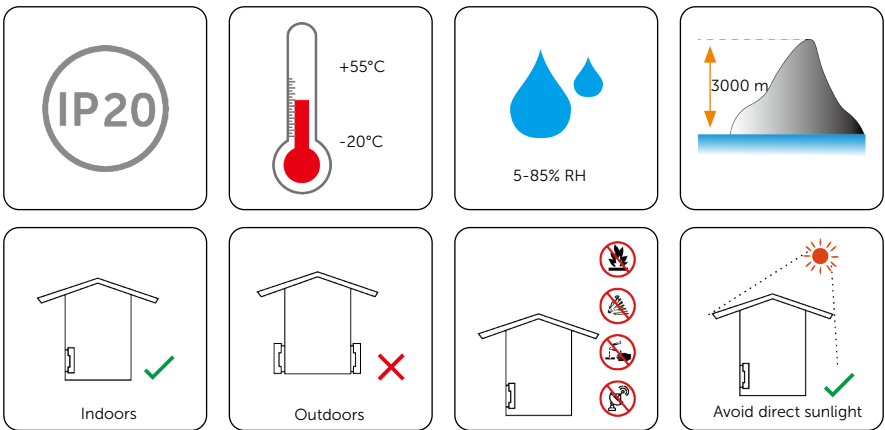

4.1.2 Installation Carrier Requirement

Make sure that the installation carrier meets the following requirements:

- **Material:** Must be made of non-combustible materials, such as solid or concrete brick. The wooden material is prohibited.
- **Load-bearing capacity:** The ground must be at least four times the weight of the battery system. The weight of battery system = "The weight of high-voltage box" + "The weight of battery packs" + "The weight of battery rack (with protective cover)". For details about the weight of battery system, see "Table 4-2 Weight about single-rack battery system", "Table 4-3 Weight about dual-rack battery system", "Table 4-4 Weight about single-rack battery system with protective cover", and "Table 4-5 Weight about dual-rack battery system with protective cover".
- **Others:** The ground must be level. The thickness of the wall must be not less than 150 mm.

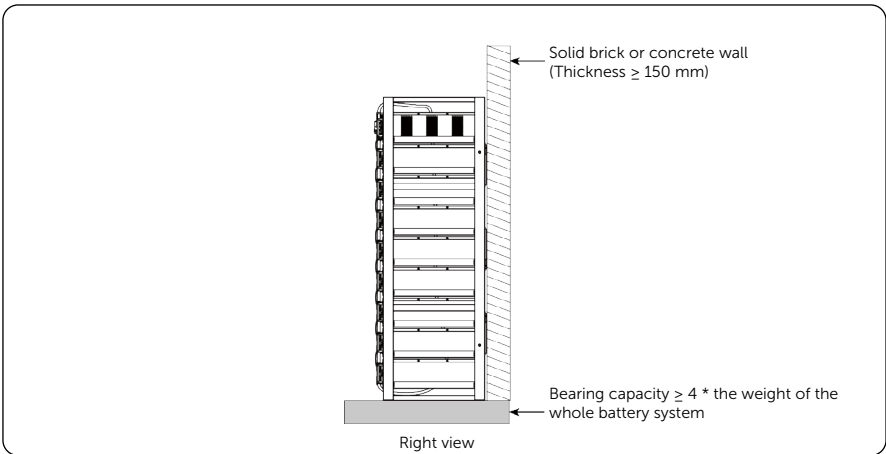

Figure 1-1 Installation carrier requirement

The following tables show the weight of battery systems in different configurations:

Table 4-2 Weight about single-rack battery system

Number of battery packs	5	6	7	8
Total weight (kg)	357.7	417.7	477.7	537.7

Table 4-3 Weight about dual-rack battery system

Number of battery packs	9	10	11	12	13	14
Total weight (kg)	636.2	696.2	756.2	816.2	876.2	936.2

Table 4-4 Weight about single-rack battery system with protective cover

Number of battery packs	5	6	7	8
Total weight (kg)	396.7	456.7	516.7	576.7

Table 4-5 Weight about dual-rack battery system with protective cover

Number of battery packs	9	10	11	12	13	14
Total weight (kg)	714.2	774.2	834.2	894.2	954.2	1014.2

Clearance Requirement

For proper heat dissipation and ease of disassembly, meet the following space requirements:

- A distance of not less than 830 mm should be provided for device installation and maintenance.
- A distance between 20 and 35 mm shall be provided between the wall and the rack for rack installation.

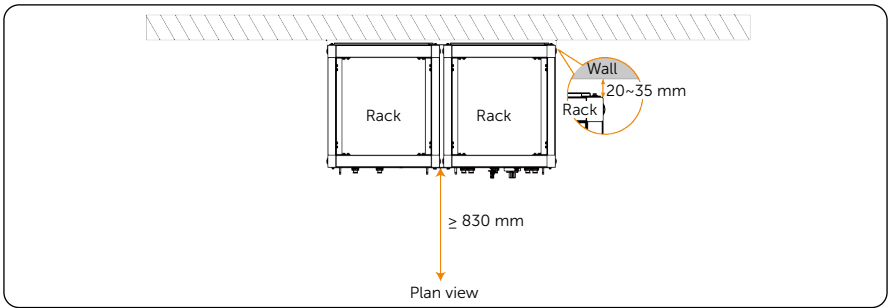
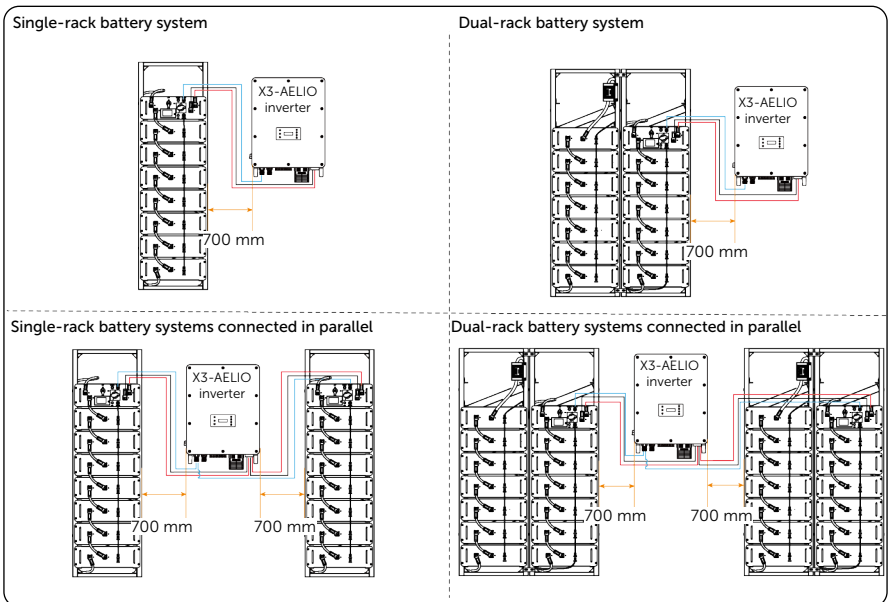

Figure 1-2 Installation space

To make the power and communication cables connected to the inverter (X3-AELIO as example) properly, keep a recommended distance between the battery and the inverter:



4.2 Tools Requirement

The installation tools include but are not limited to the following. If necessary, use other appropriate tools on site.

Installation tools

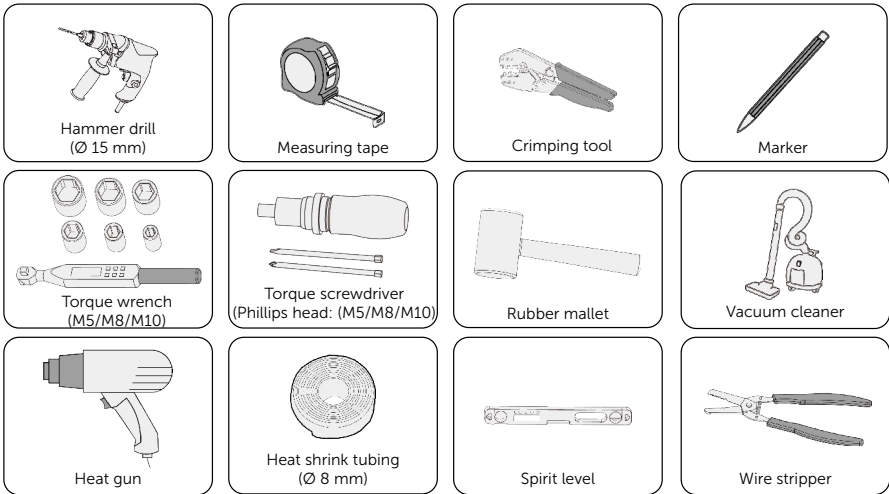

Personal protective equipment

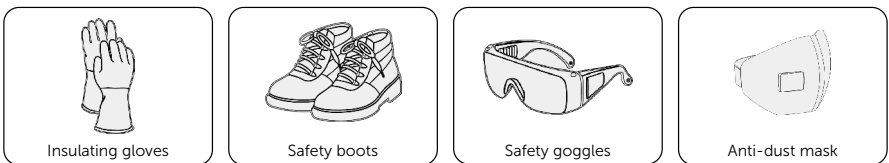

4.3 Additionally Required Materials

Please prepare the following materials by yourself:

Table 4-1 Additionally required materials

Name	Appearance	Conductor cross-section
Conventional yellow and green PE cable		25 mm ²

5 Unpacking and Inspection

5.1 Unpacking

- The rechargeable battery undergoes 100% testing and inspection before shipping from the manufacturing facility. However, transport damage may still occur. Before unpacking the rechargeable battery, please verify that the model and outer packing materials for damage, such as holes and cracks.
- Unpack a high-voltage carton as shown below. The methods for unpacking the other cartons are similar, which are not described in detail herein.

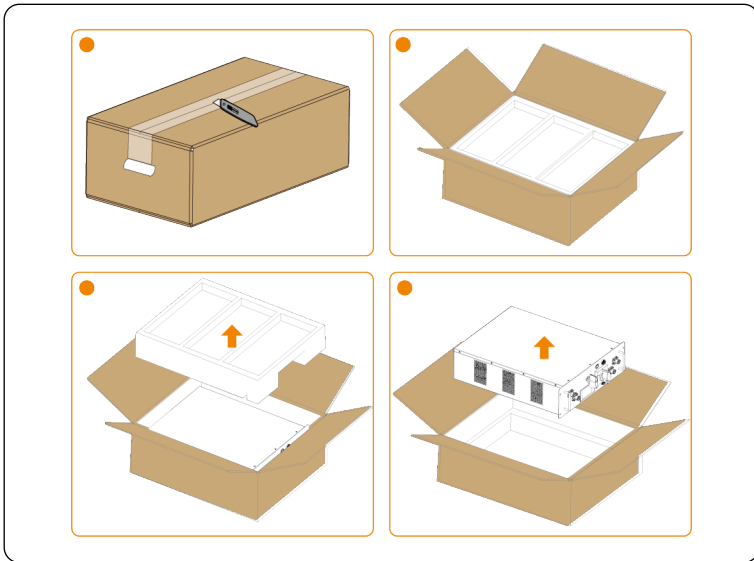

Figure 5-1 Unpacking the high-voltage box

- Be careful when dealing with all package materials which may be reused for storage and relocation of the rechargeable battery in the future.
- Upon opening the package, check whether the appearance of the rechargeable battery is damaged or lack of accessories. If any damage is found or any parts are missing, contact your dealer immediately.

5.2 Scope of Delivery

The packing list varies with your battery configuration. See the following table for details.

Table 5-1 Types of packing lists

Option	Packing List			
	Rack	High-voltage box	Battery pack	Additional delivery
Single-rack battery system	1	1	√	/
Dual-rack battery system	2	1	√	1

√: The number of parts varies with your configuration.



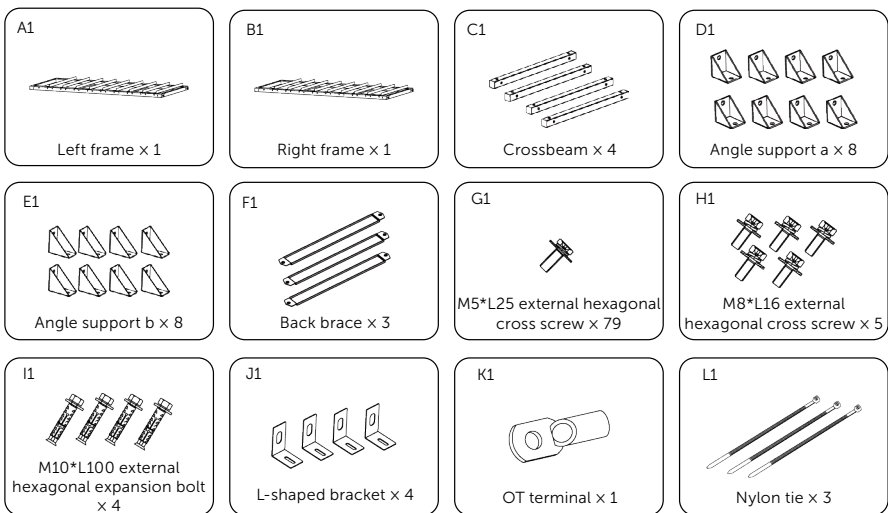





Battery rack





NOTICE!

- The parts shown above are only for one pack. Purchase battery racks as needed.
- If the number of your packs is between 9 and 14, two racks are needed.

High-voltage box

 <p>High-voltage box x 1</p>	<p>A2</p>  <p>Power cable High-voltage box to pack (+ to +) (orange) (85 mm) x 1</p>	<p>B2</p>  <p>Power cable High-voltage box to pack (- to -) (black) (2300 mm) x 1</p>	<p>C2</p>  <p>BMS-to-PCS power cable (+) (2000 mm) x 1</p>
<p>D2</p>  <p>BMS-to-PCS power cable (-) (2000 mm) x 1</p>	<p>E2</p>  <p>Terminating resistor x 1</p>	<p>F2</p>  <p>Communication cable (BMS port) (2000 mm) x 1</p>	<p>G2</p>  <p>Document</p>

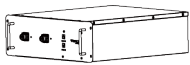

Battery pack

 <p>Battery pack x 1</p>	<p>A3</p>  <p>Communication cable (110 mm) x 1</p>	<p>B3</p>  <p>Power cable (pack to pack) (100 mm) x 1</p>
---	---	--

NOTICE!

- The parts shown above are for one pack only. Purchase battery packs as needed.

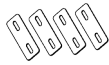
Additional delivery (for connection of dual-rack battery system)

<p>A4</p>  <p>M5*L25 external hexagonal cross screw x 8</p>	<p>B4</p>  <p>Adjustable bracket x 4</p>	<p>C4</p>  <p>Communication cable (Pack to pack) (2030 mm) x 1</p>	<p>D4</p>  <p>Power cable (Pack to pack) (- to +) (2030 mm) (orange&black) x 1</p>
--	---	---	---

Capacity expansion (optional)

A5



BMS-to-PCS power cable
(+) (orange) (2300 mm)
x 1

B5



BMS-to-PCS power cable
(-) (black) (2300 mm)
x 1

NOTICE!

- If your X3-AELIO series inverter is to connect battery towers in parallel, contact us to purchase the capacity expansion kit.

6 Installation and Wiring for Single-Rack Battery System

WARNING!

- Check the existing power cables or other piping in the wall, to prevent electric shock.
- Keep aware of the battery weight. **Three persons** are recommended to install the battery system. Otherwise, personal injuries may be caused by improper lift or falling during transportation or mounting. For details about weight, see "2.2.1 Product Dimensions and Weight".

NOTICE!

- Only the qualified personnel can install the battery system.
- Install the battery system according to the local standards and requirements.
- During battery installation and maintenance, use insulated tools and PPE (Personal Protective Equipment).

Please install the battery system strictly according to the layout below.

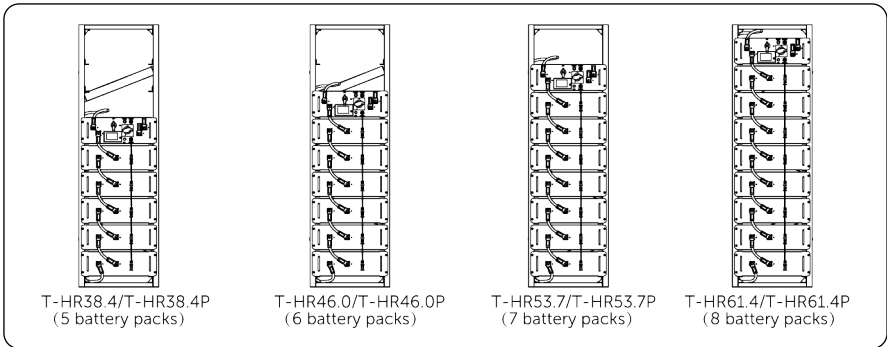

Figure 6-2 Layout of single-rack battery system (5-8 battery packs)

* The models with "P" are battery systems delivered with rack protection cover.

6.1 Installation for Single-Rack Battery System

Step 1: Take crossbeams (part C1), angle supports (parts D1 and E1), M5 screws from the accessory kit. Attach angle supports to each beam and tighten them with screws M5 (part G1) (torque: 3 ± 0.3 N·m).

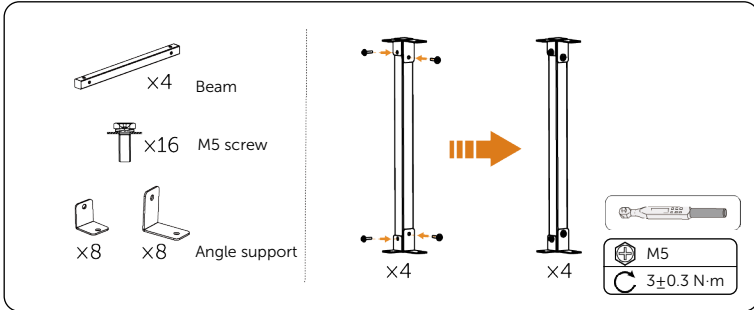

Figure 6-3 Assembling crossbeams

Step 2: Place left and right frames (part A1 and B1) onto the level ground. Take screws M5 (part G1) from the accessory kit and connect frames and beams with screws. Before inserting the last screw into a preserved hole, pre-tighten all screws. Then fully tighten all screws with a torque wrench (torque: 3 ± 0.3 N·m).

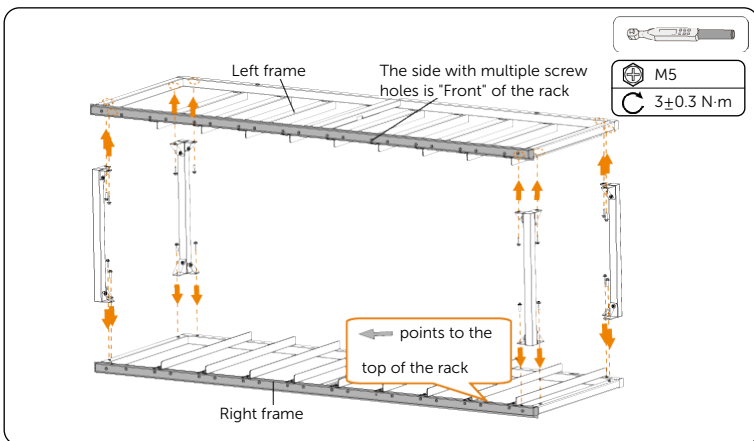

Figure 6-4 Connecting frames

Step 3: Place back braces (part F1) onto the back of rack. Tighten them with a torque wrench (torque: 3 ± 0.3 N·m).

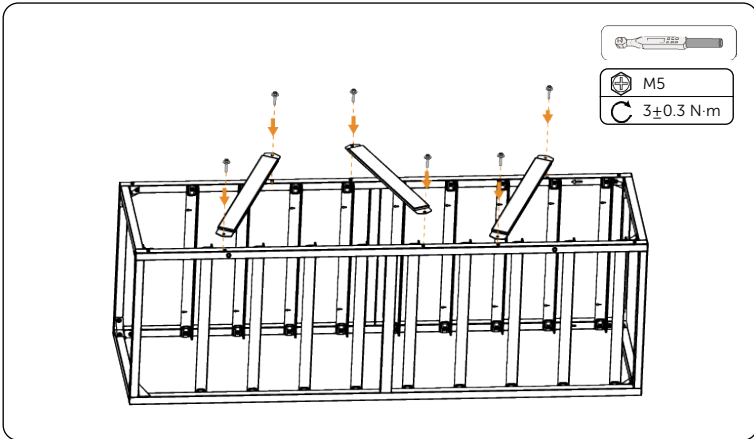

Figure 6-5 Assembling the back brace

Step 4: Stand the racks up with the cooperation of two persons. Place the racks against the wall where they are to be installed. Ensure the ground is level and firm.

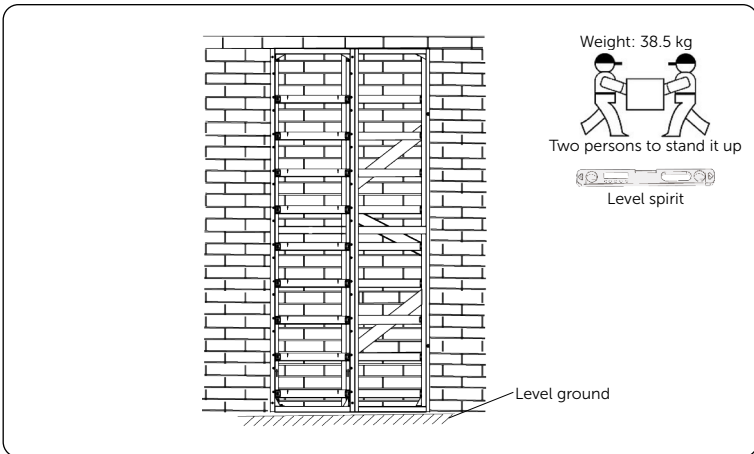

Figure 6-6 Standing the rack up

Step 5: Attach L-shaped brackets (part J1) to preserved holes of the rack. Insert M8 screws (part H1) (4 pcs) into the holes and pre-tighten them.

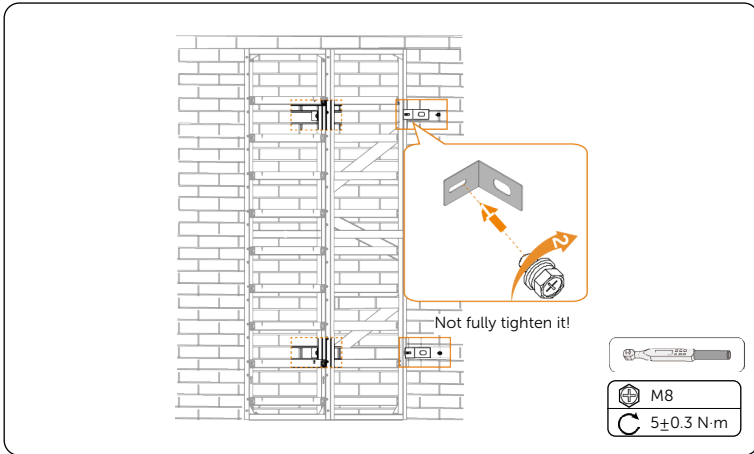

Figure 6-7 Assembling L-shaped brackets

NOTICE!

- Ensure that L-shaped brackets are flush with the wall before pre-tightening screws.

Step 6: Draw circles along the inner edge of the holes of the L-shaped brackets on the wall. And then move the rack away from the wall, to drill holes for brackets.

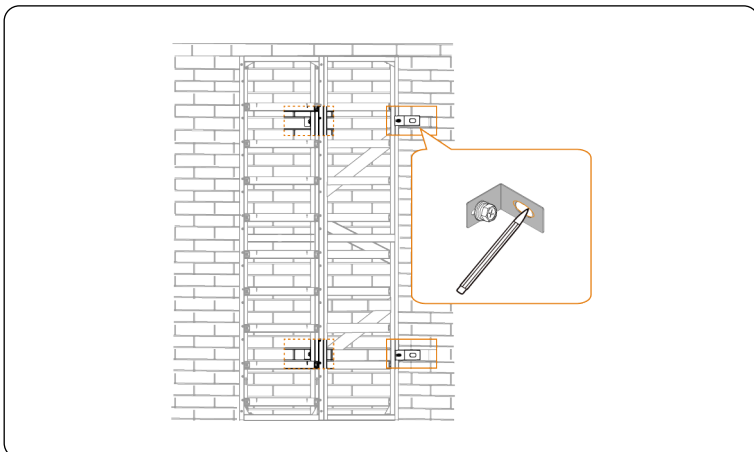

Figure 6-8 Drawing circles on the wall

Step 7: Drill holes at the previously marked positions.

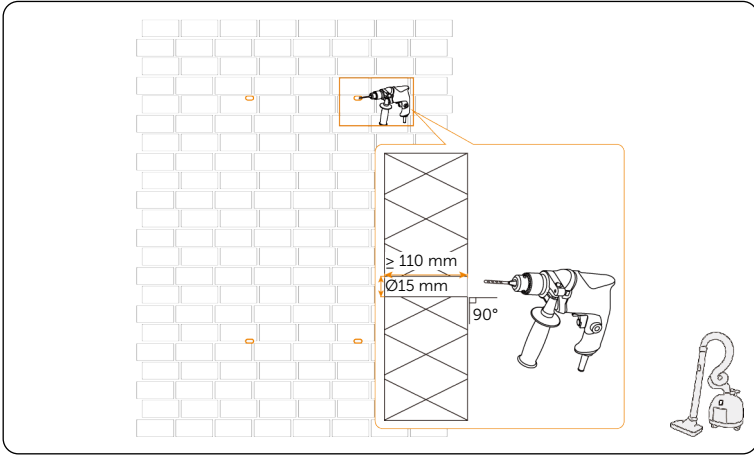

Figure 6-9 Drilling holes

NOTICE!

- During drilling, cover the rack with the package bag or other materials, to prevent dust from falling onto it.
- After drilling, if there is any dust on the rack, wall or ground, clean it with a dust vacuum.

Step 8: Use a rubber hammer to drive the four M10 expansion screws (part I1) into the previously drilled holes separately, and then tighten them clockwise with a torque wrench (torque: $24 \pm 2.4\text{ N}\cdot\text{m}$). Fully tighten the four M8 screws (torque: $12 \pm 1.2\text{ N}\cdot\text{m}$).

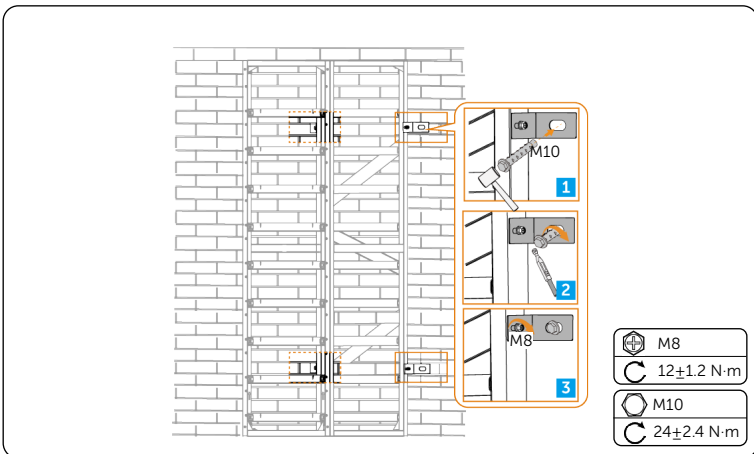

Figure 6-10 Tightening rack to wall

Step 9: According to the recommended layout of single-rack battery system, place the battery packs and high-voltage box into the rack from bottom to top with the cooperation of three persons.

- If the number of packs = 8, place battery packs and high-voltage box as shown in the figure.

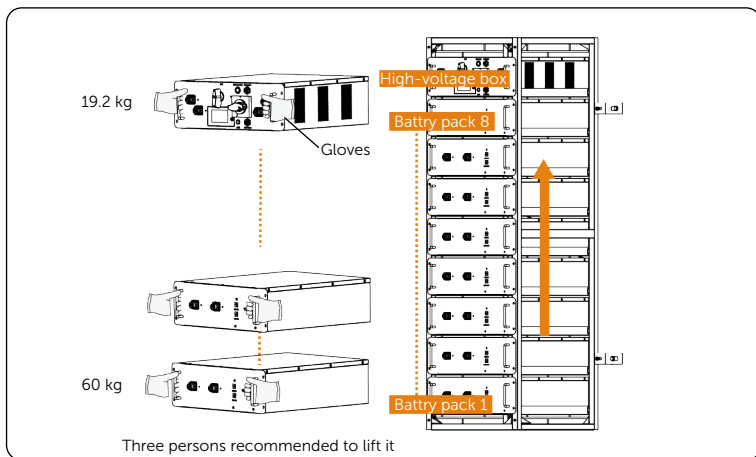

Figure 6-11 Placing battery system into the rack

- If $5 \leq$ the number of packs < 8 (take 5 battery packs as an example), follow steps below:
 - a. Place battery backs into the rack.

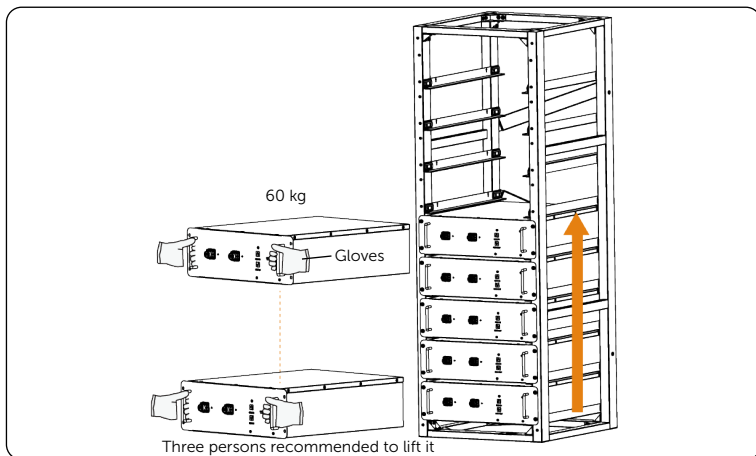

Figure 6-12 Placing battery packs into the rack

- b. Adjust the layer height for the high-voltage box by dismantling and reinstalling the support.

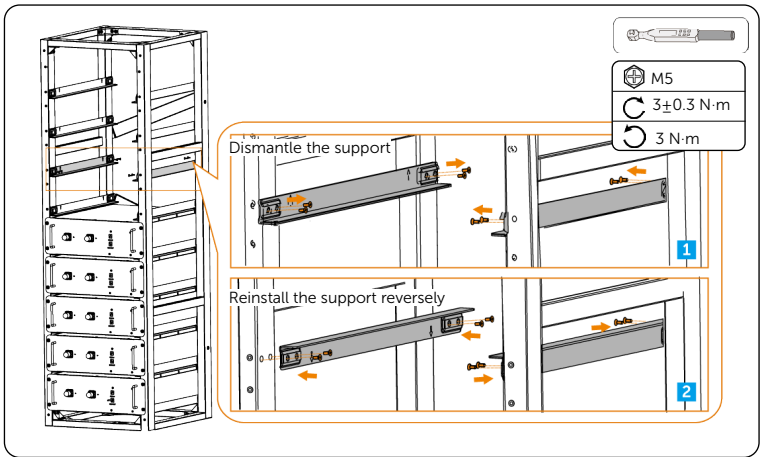

Figure 6-13 Adjusting the layer height for high-voltage box

- c. Place the high-voltage box into the already adjusted layer.

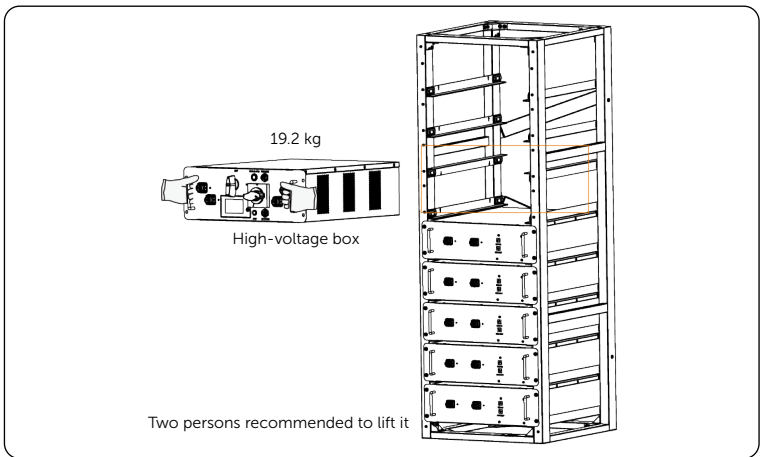

Figure 6-14 Placing high-voltage box into rack

Step 10: Tighten the battery with screws M5 (part G1) with a torque wrench.

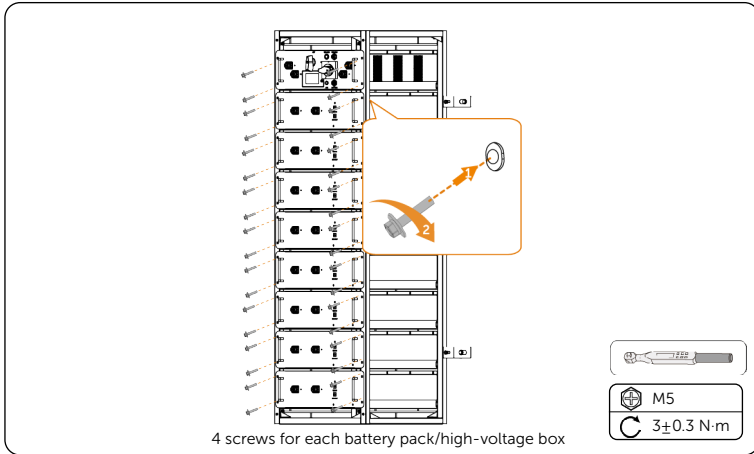

Figure 6-15 Securing the battery

6.2 Wiring for Single-Rack Battery System

NOTICE!

- Before electrical connection, check whether all cables are well delivered or prepared.

Cables between the battery system and inverter are shown below.

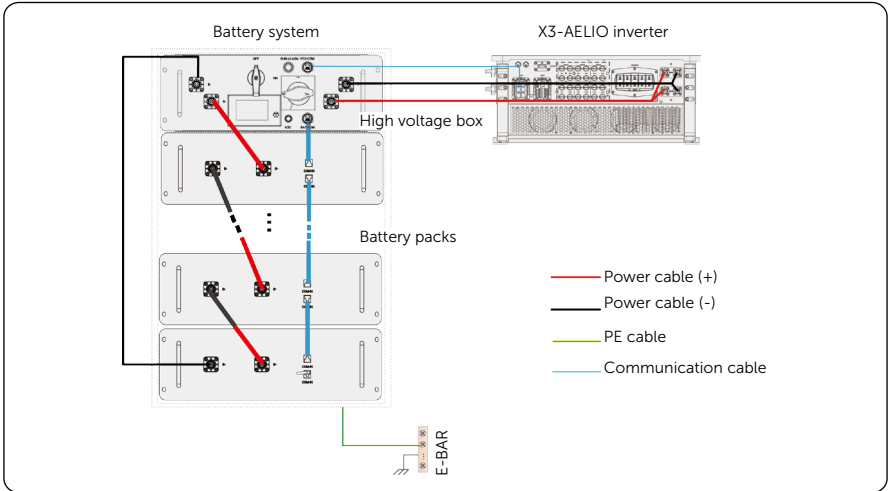

Figure 6-16 Wiring diagram of single-rack battery system

6.2.1 PE Connection



- Connect the PE cable securely, to avoid electrical shocks, device damages, or fire disasters.

Step 1: Strip the insulation layer from the PE cable in a proper length.

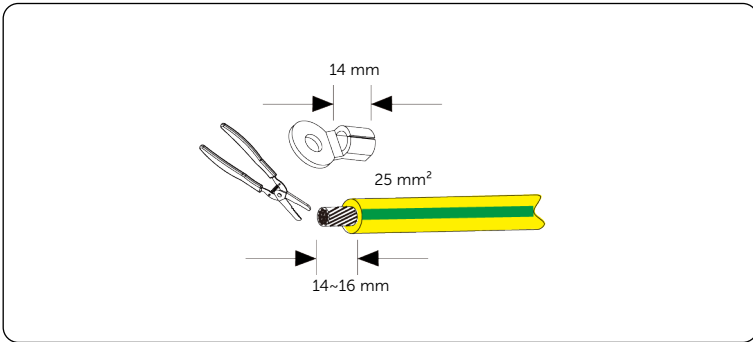

Figure 6-17 Striping the insulation layer

Step 2: Cut a heat-shrink tubing with a length of 28 to 30 mm. Sleeve the PE cable with the heat-shrink tubing and then pull the heat-shrink tubing to the right.

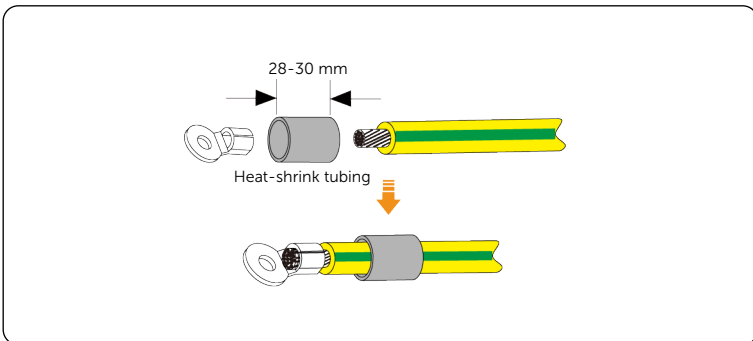

Figure 6-18 Cutting heat-shrink tubing

Step 3: Crimp the terminal and the cable core together. And then heat the heat-shrink tubing after it wraps the crimped end.

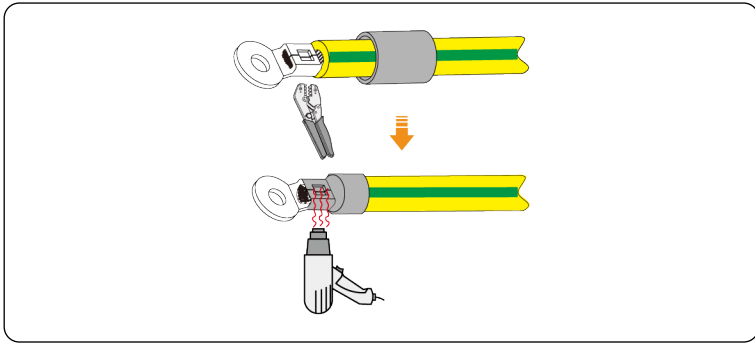

Figure 6-19 Crimping and heating

NOTICE!

- Do not put the conductor insulation into the terminal.
- Do not damage the conductor insulation while crimping.
- Move the heat gun back and forth slowly to heat the heat-shrink tubing evenly.

Step 4: Connect the PE cable to the grounding point on the left or right frame with an M8 screw.

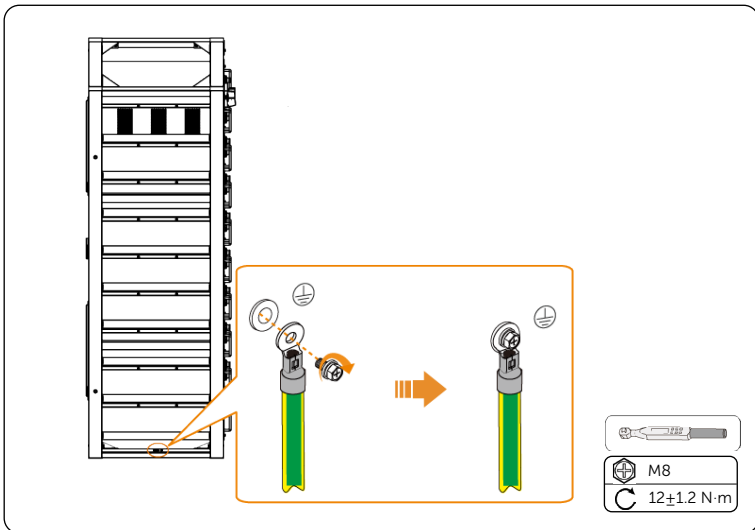

Figure 6-20 Connecting one end of PE cable

Step 5: Connect the other end of the PE cable to a copper bar or brass terminal.

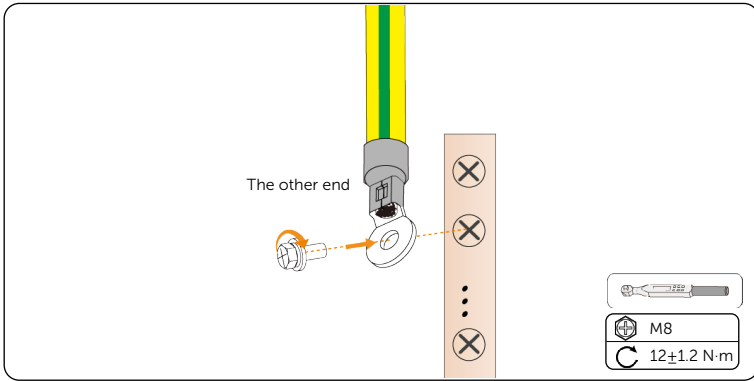

Figure 6-21 Connecting the other end of PE cable

6.2.2 Communication Cable Connection

Step 1: Use a communication cable (part A3) to connect the high-voltage box and its neighbouring pack.

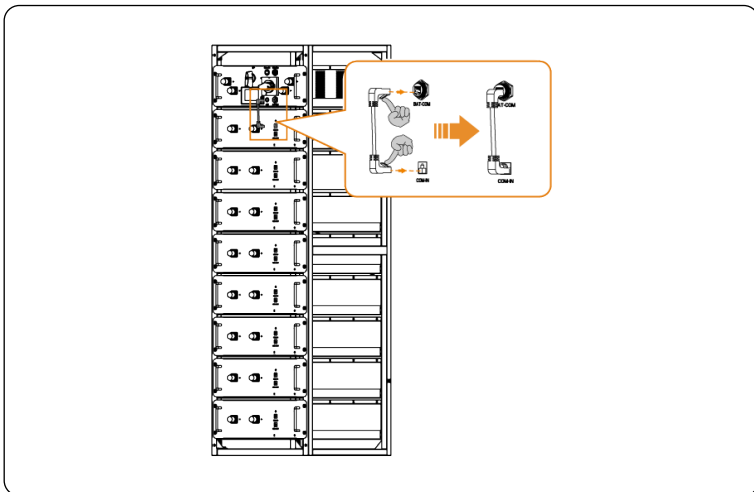

Figure 6-22 Connecting high-voltage box and its neighbouring battery pack

Step 2: From top to bottom, connect the other packs in the same way.

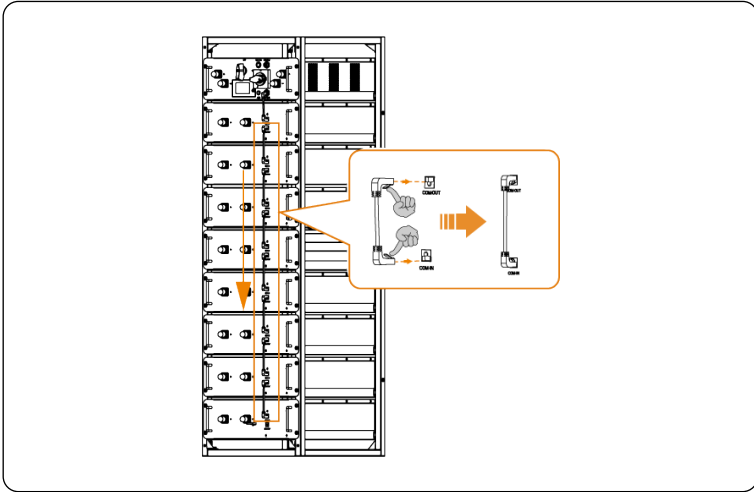

Figure 6-23 Connecting the other packs

Step 3: Insert the terminating resistor (part E2) into port **COM-OUT** of the last pack.

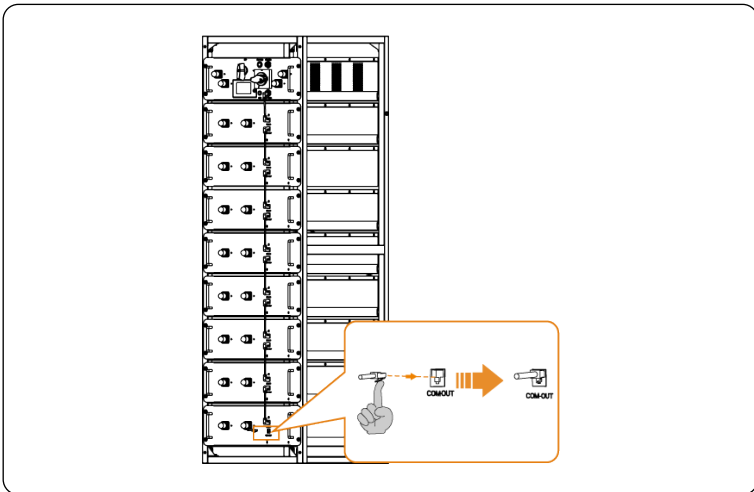

Figure 6-24 Inserting terminating resistor

6.2.3 Power cable connection



- When installing the power cable, connect the negative end first and then positive end, to ensure your personal safety.

Step 1: Take dust-proof covers down from all **B+** and **B-** ports of the battery systems. Keep them properly for further use.

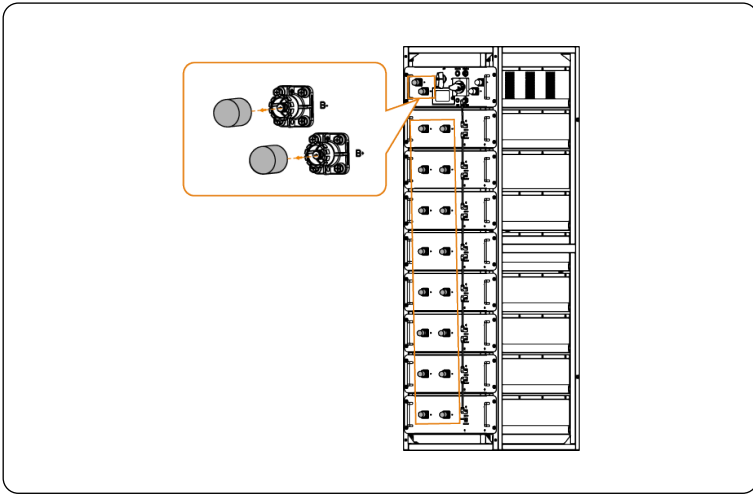

Figure 6-25 Taking dust-proof covers down

Step 2: Use a power cable (part A2) to connect ports **B+** of the high-voltage box and its neighbouring battery pack.

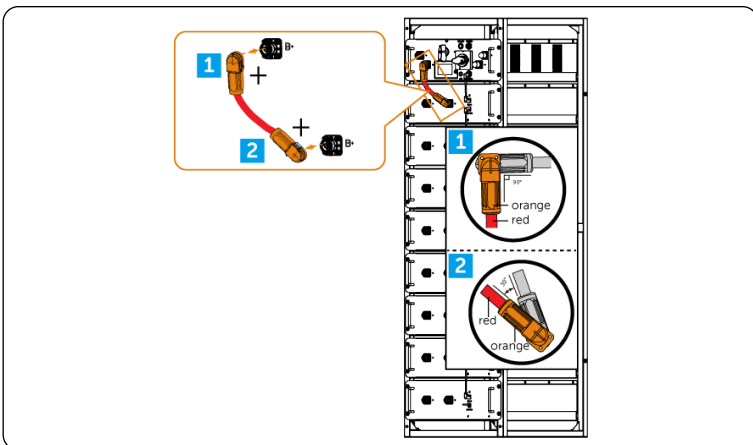

Figure 6-26 Connecting high-voltage box and its neighbouring pack

Step 3: From top to bottom, connect port **B-** of the first pack and port **B+** of the second pack with a power cable (part B3). Repeat the operation until you connect to port **B+** of the last pack.

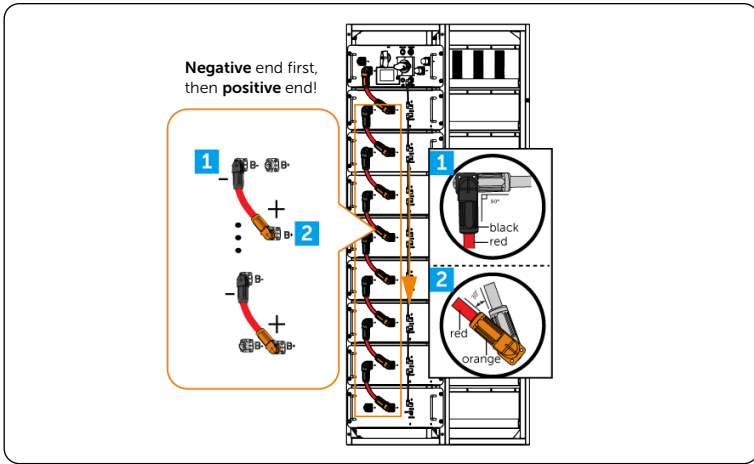

Figure 6-27 Connecting packs

Step 4: Use a power cable (part B2) to connect port **B-** of the LAST battery pack and port **B-** of the high-voltage box.

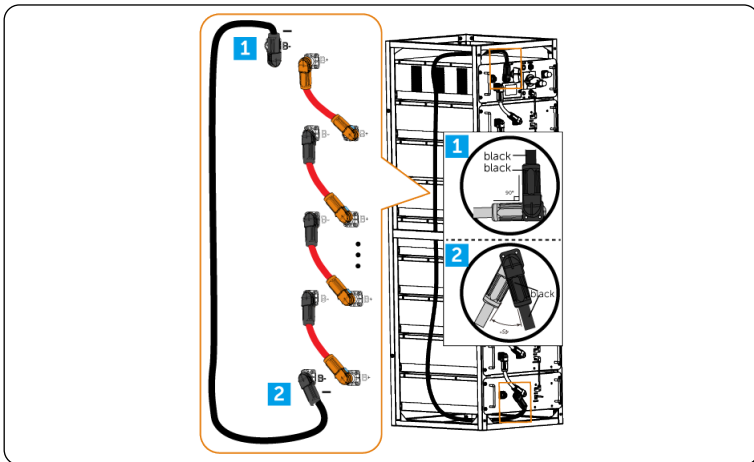

Figure 6-28 Connecting high-voltage box and the last pack

Step 5: Fasten the long power cable to the support of the rack with a nylon tie (part L1).

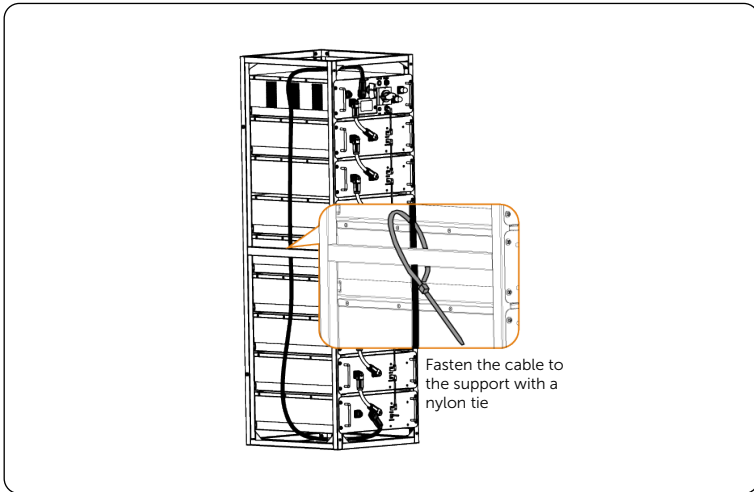

Figure 6-29 Fastening cable to support

 CAUTION!

- During installation, do not remove the power cables forcibly. Otherwise, it will damage the cable connector. The correct removal method:



6.2.4 Connection to Inverter

Power cable connection

Step 1: Take dust-proof covers from ports **P+** and **P-** on the high-voltage box. Keep them properly for further use.

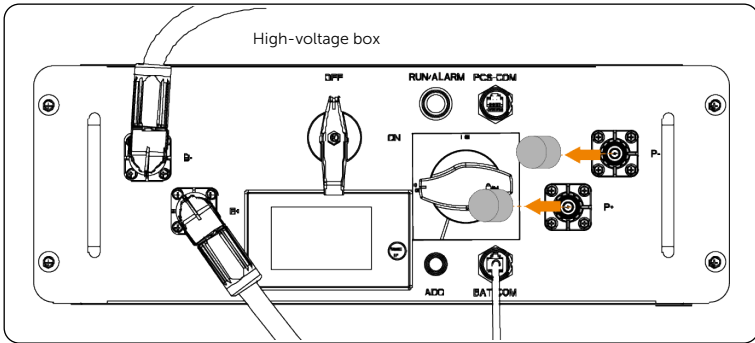

Figure 6-30 Taking dust-proof covers down

Step 2: Take positive and negative power cables (parts C2 and D2) from the accessory kit. Connect one end of the positive and negative power cables to ports **P+** and **P-** separately.

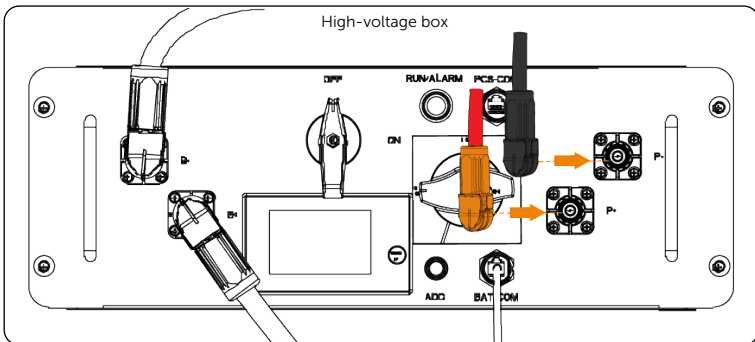

Figure 6-31 Connecting one end to battery

Step 3: Connect the other end of the positive and negative power cables to ports **BAT 1** and **BAT2** of the inverter.

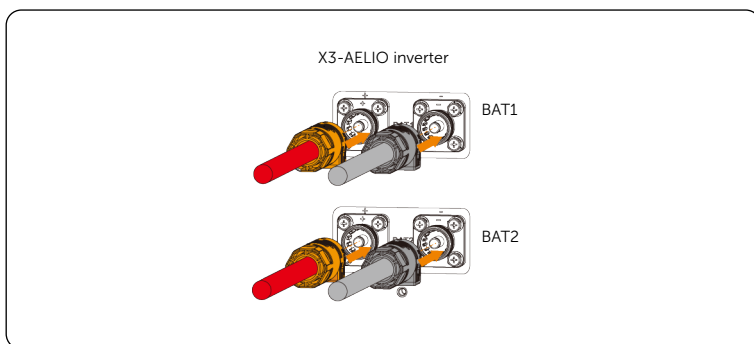

Figure 6-32 Connecting the other end to inverter

NOTICE!

- The power cables (parts C2 and D2), which are one-to-two cables, are only for one-battery-tower connection. For two-battery-tower parallel connection, use one-to-one power cables in the expansion capacity kit.

Communication cable connection

Step 1: Take the communication cable (part F2) from the accessory kit for high-voltage box. Connect one end of the cable to port **PCS COM** of the high-voltage box.

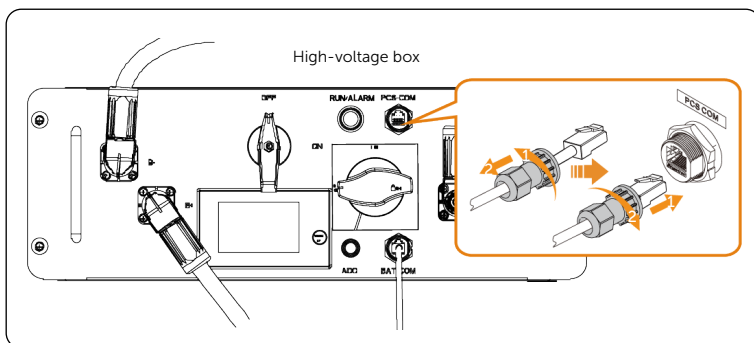

Figure 6-33 Connecting one end to battery

Step 2: Insert the other end of the cable into support **BMS1** or **BMS1** of port **COM1** on the inverter (take X3-AELIO inverter as an example).

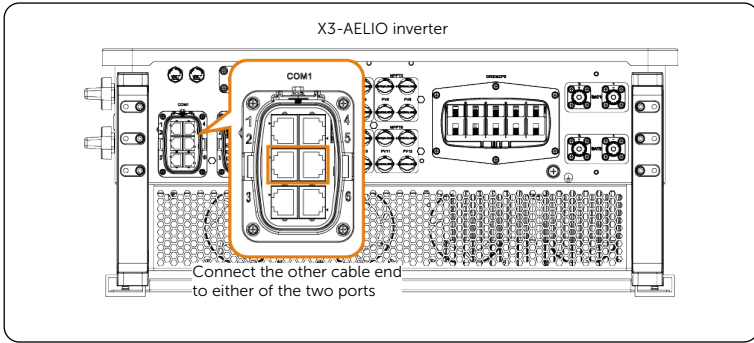

Figure 6-34 Connecting to inverter

NOTICE!

- For details about connecting to X3-AELIO inverter, see *X3-AELIO Series User Manual*.

Related operation

If the communication cable (part F2) we provide for you is not long enough, follow steps below to make one by yourself:

Step 1: Prepare a standard communication cable and an RJ-45. Cut the provided communication cable (part F2) to get the waterproof cap.

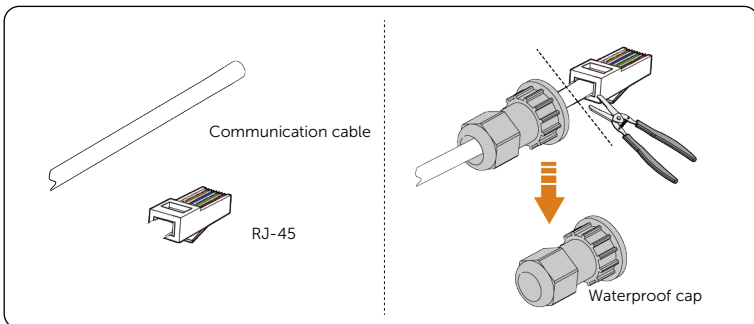

Figure 6-35 Preparing materials

Step 2: Thread the prepared communication cable through the waterproof. Strip the cable jacket off 15 mm.

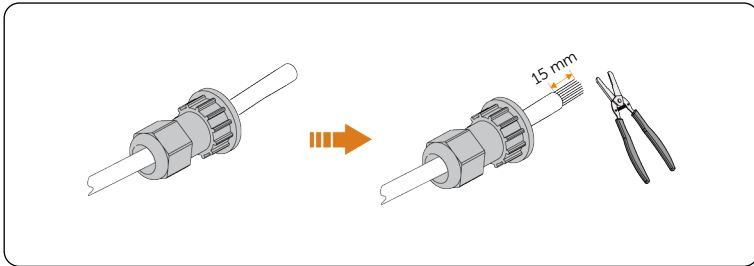

Figure 6-36 Stripping cable jacket

Step 3: To ensure pin-to-pin connection to the inverter, process one end of the cable according to the pin definition of battery communication port. Then thread cores into the RJ-45 and crimp them together.

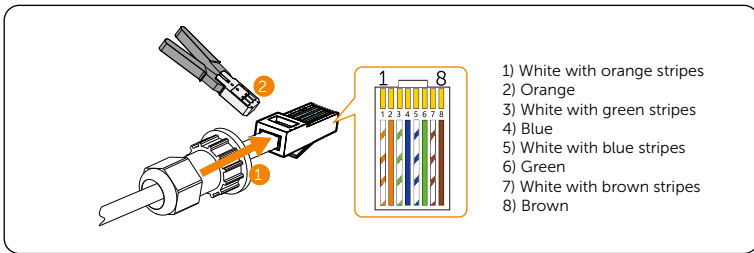

Figure 6-37 Crimping RJ45

Table 6-2 Pin assignment of battery port **PCS COM**

Pin No.	1	2	3	4	5	6	7	8
Definition	DO+	DO-	DI-	CANH	CANL	DI+	NC	NC

Step 4: Process the other end of the cable according to the pin definition of inverter communication port (take X3-AELIO inverter as an example). Then thread cores into the RJ-45 and crimp them together. For more details, see the corresponding inverter user manual.

Table 6-3 Pin assignment of inverter port **BMS** (X3-AELIO inverter)

Pin No.	1	2	3	4	5	6	7	8
Definition	BAT-TEMP	GND-COM	GND-COM	BMS1-CANH	BMS1-CANL	BAT_WAKEUP_POWER	BMS_485A	BMS_485B

7 Installation and Wiring for Dual-Rack Battery System

WARNING!

- Check the existing power cables or other piping in the wall, to prevent electric shock.
- Keep aware of the battery weight. **Three persons** are recommended to install the battery system. Otherwise, personal injuries may be caused by improper lift or falling during transportation or mounting. For details about weight, see ["2.2.1 Product Dimensions and Weight"](#).

NOTICE!

- Only the qualified personnel can install the battery system.
- Install the battery system according to the local standards and requirements.
- During battery installation and maintenance, use insulated tools and PPE (Personal Protective Equipment).

Please install the battery system strictly according to the layout drawing below.

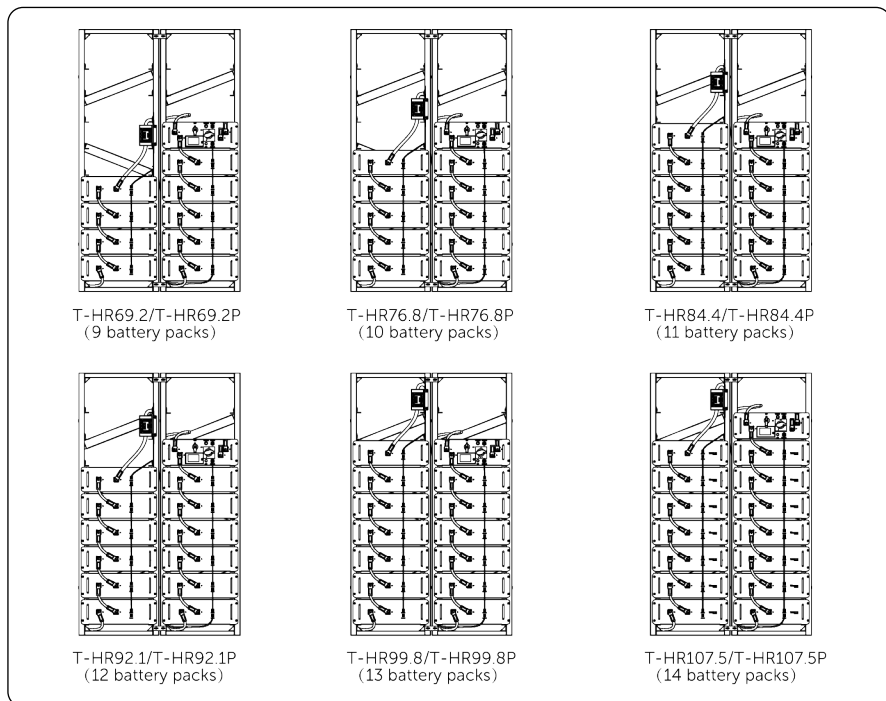

Figure 7-38 Layout of dual-rack battery system (9~14 battery packs)

* The models with "P" are battery systems delivered with rack protection cover.

7.1 Installation for Dual-Rack Battery System

Step 1: Take crossbeams (part C1), angle supports (parts D1 and E1), M5 screws from the accessory kit. Attach angle supports to each beam and tighten them with screws M5 (part G1) (torque: 3 ± 0.3 N·m).

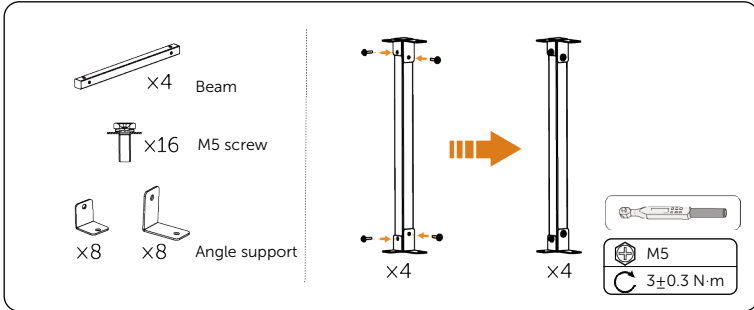

Figure 7-39 Assembling crossbeams

Step 2: Place left and right frames (part A1 and B1) onto the level ground. Take screws M5 (part G1) from the accessory kit and connect frames and beams with screws. Before inserting the last screw into a preserved hole, pre-tighten all screws. Then fully tighten all screws with a torque wrench (torque: 3 ± 0.3 N·m).

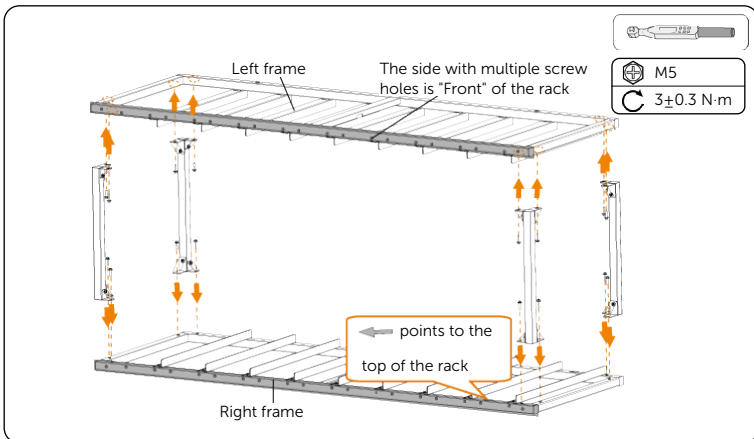

Figure 7-40 Connecting frames

Step 3: Place back braces (part F1) onto the back of rack. Tighten them with a torque wrench (torque: 3 ± 0.3 N·m).

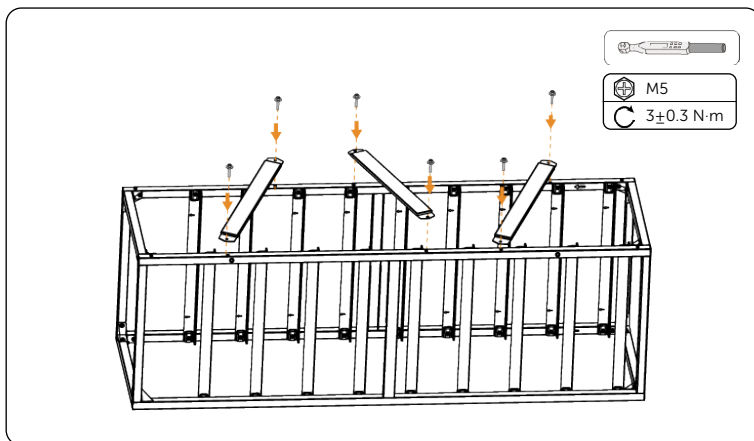

Figure 7-41 Assembling the back brace

Step 4: Stand the racks up with the cooperation of two persons. Place the racks against the wall where they are to be installed. Ensure the ground is level and firm.

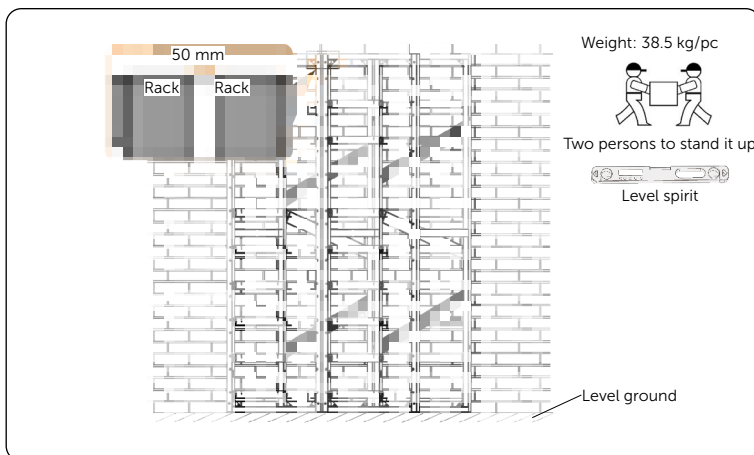

Figure 7-42 Standing rack up

Step 5: Fasten the two racks together with adjustable brackets (part B4).

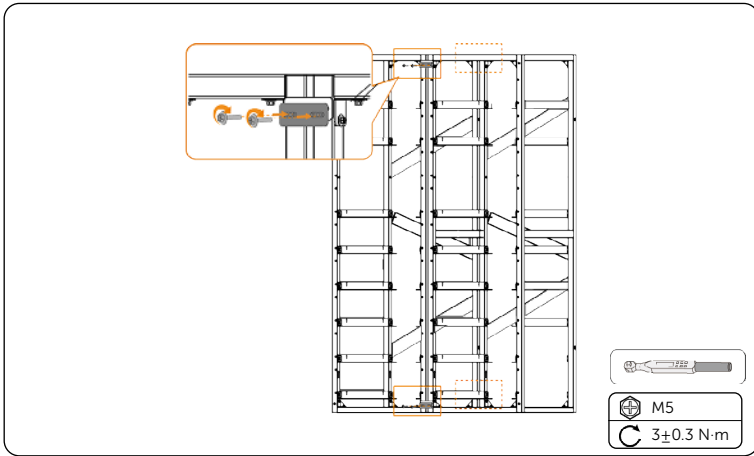

Figure 7-43 Fastening racks

Step 6: Attach L-shaped brackets (part J1) to preserved holes of the rack. Insert M8 screws (part H1) (4 pcs) into the holes and pre-tighten them.

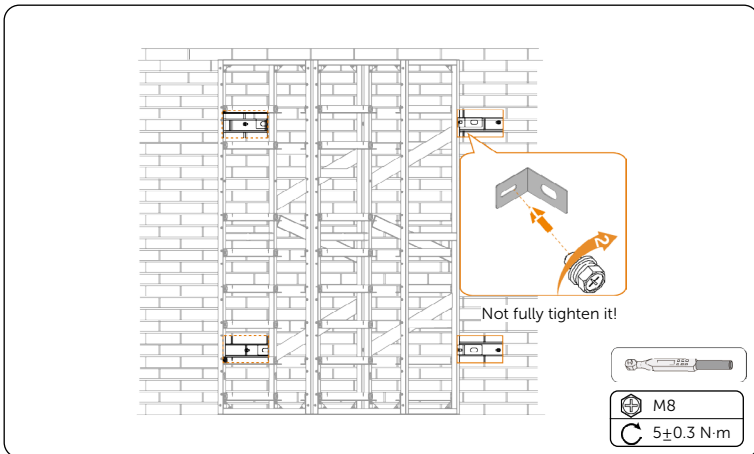

Figure 7-44 Assembling L-shaped brackets

NOTICE!

- Ensure that L-shaped brackets are flush with the wall before pre-tightening screws.

Step 7: Draw circles along the inner edge of the holes of the L-shaped brackets on the wall. And then move the racks away from the wall, to drill holes for brackets.

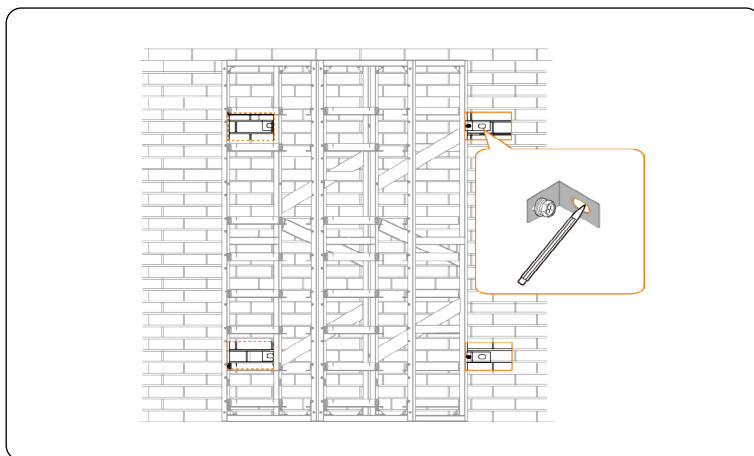

Figure 7-45 Drawing circles on the wall

Step 8: Drill holes at the previously marked positions.

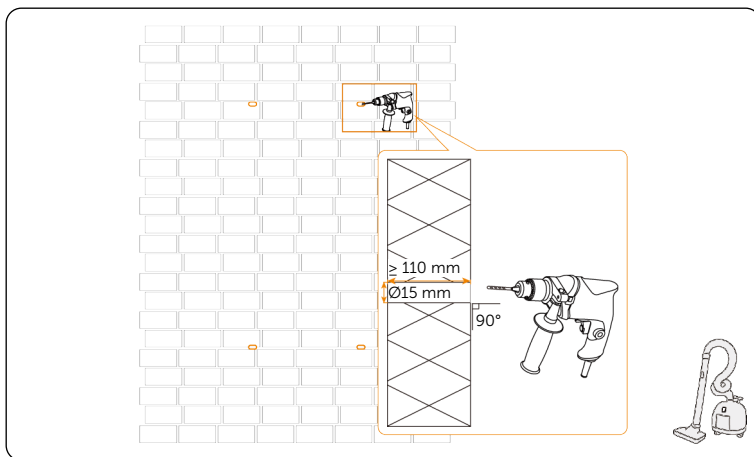

Figure 7-46 Drilling holes

NOTICE!

- During drilling, cover the rack with the package bag or other materials, to prevent dust from falling onto it.
- After drilling, if there is any dust on the rack, wall or ground, clean it with a dust vacuum.

Step 9: Use a rubber hammer to drive the four M10 expansion screws (part I1) into the four drilled holes separately, and then tighten them clockwise with a torque wrench (torque: 24 ± 2.4 N·m). Fully tighten the four M8 screws (torque: 12 ± 1.2 N·m).

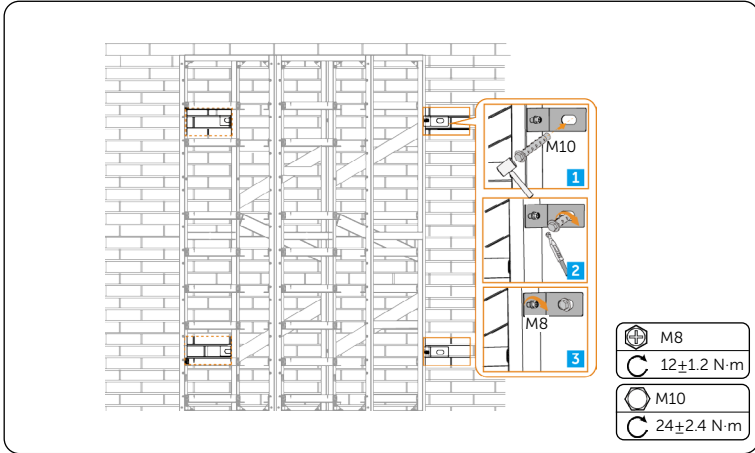

Figure 7-47 Tightening rack to wall

Step 10: According to the recommended layout of dual-rack battery system (here take dual-rack battery system with 11 packs as an example), place the high-voltage box and battery packs into the two racks.

a. Place battery packs into the rack from bottom to top and reserve the layer for the high-voltage box.

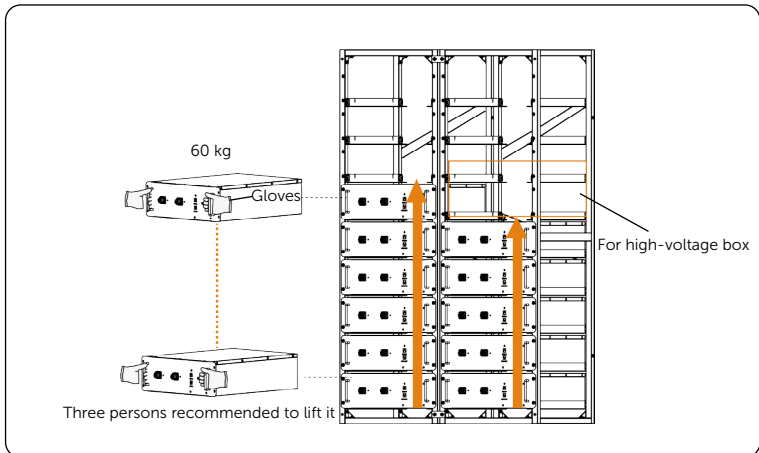

Figure 7-48 Placing packs into racks

b. Dismantle the upper support of the layer where the high-voltage box is to be placed, and reinstall the support reversely to make the height of the layer fit the height of the high-voltage box.

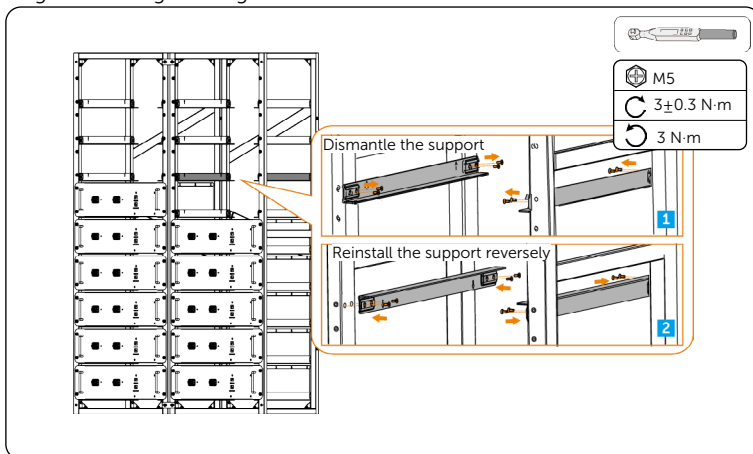

Figure 7-49 Preparing enough space for high-voltage box

c. Place the high-voltage box into the already adjusted layer.

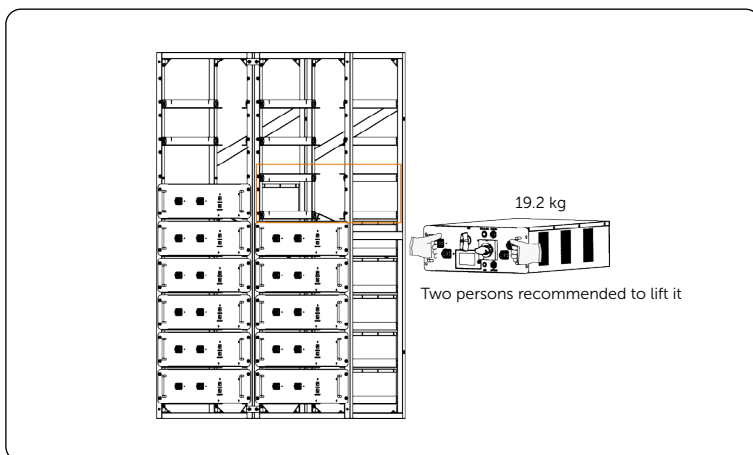

Figure 7-50 Installing the high-voltage box

Step 11: Tighten the battery with screws M5 (Part J) with a torque wrench.

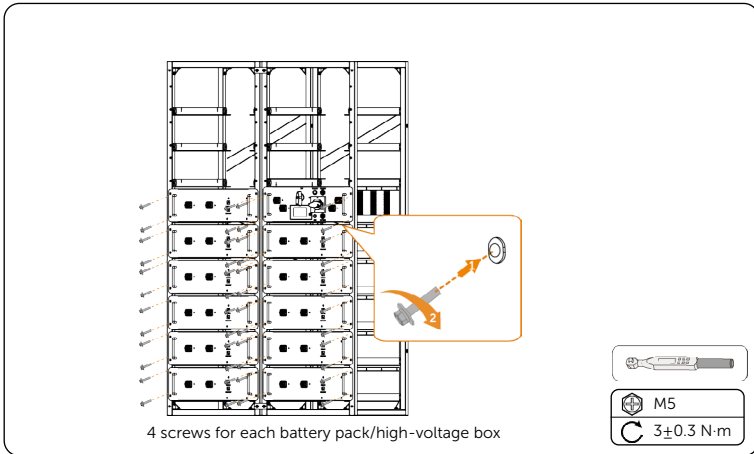

Figure 7-51 Securing the battery

7.2 Wiring for Dual-Rack Battery System

NOTICE!

- Before electrical connection, check whether all cables are well delivered or prepared.

Cables between the battery system and inverter are shown below.

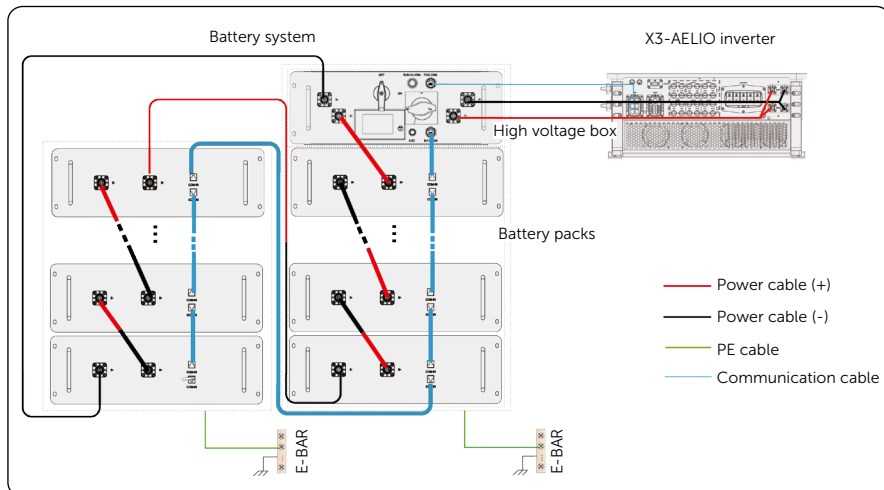

Figure 7-52 Wiring diagram of dual-rack battery system

7.2.1 PE Connection



- Connect the PE cable securely, to avoid electrical shocks, device damages, or fire disasters.

Step 1: Strip the insulation layer from the PE cable in a proper length.

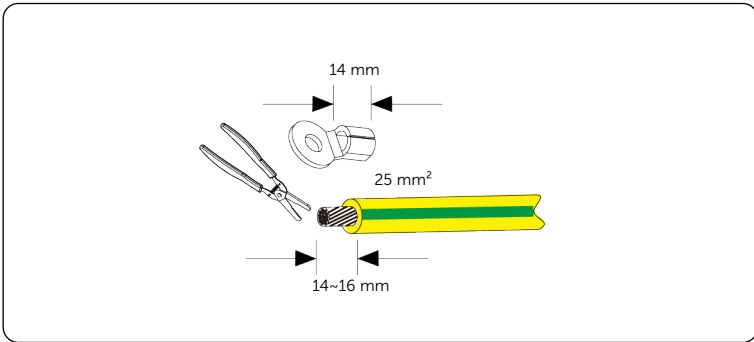

Figure 7-53 Striping the insulation layer

Step 2: Cut a heat-shrink tubing with a length of 28 to 30 mm. Sleeve the PE cable with the heat-shrink tubing and then pull the heat-shrink tubing to the right.

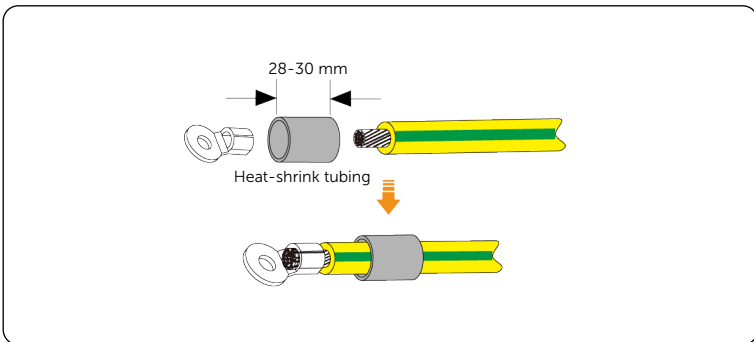

Figure 7-54 Cutting heat-shrink tubing

Step 3: Crimp the terminal and the cable core together. And then heat the heat-shrink tubing after it wraps the crimped end.

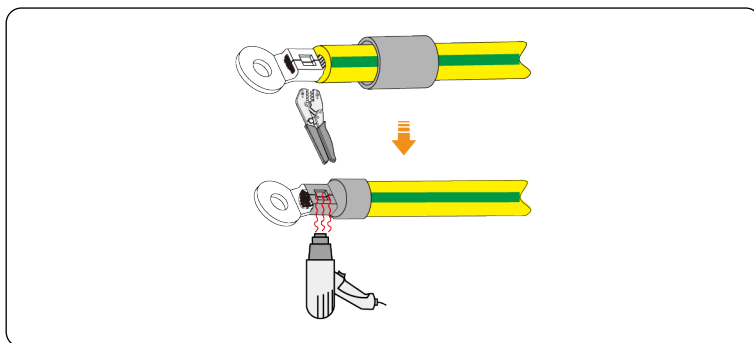

Figure 7-55 Crimping and heating

NOTICE!

- Do not put the conductor insulation into the terminal.
- Do not damage the conductor insulation while crimping.
- Move the heat gun back and forth slowly to heat the heat-shrink tubing evenly.

Step 4: Connect the PE cable to grounding points on both sides of the dual-rack system with M8 screws.

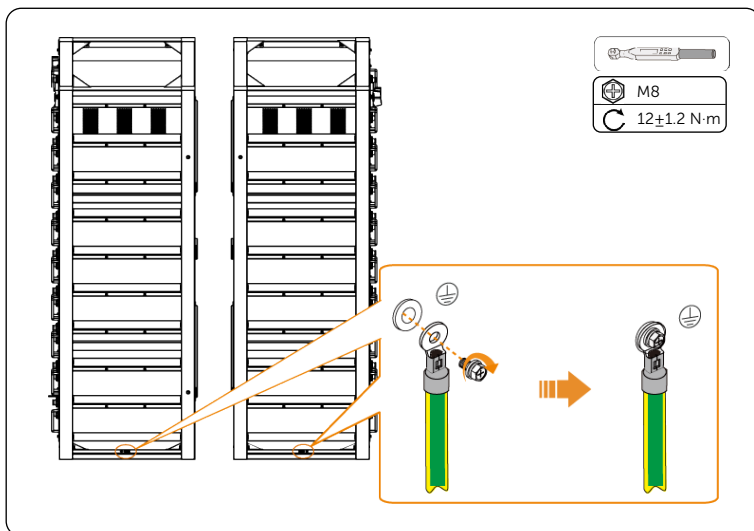

Figure 7-56 Connecting one end of grounding cable

Step 5: Connect the other end of the PE cable to a copper bar or brass terminal.

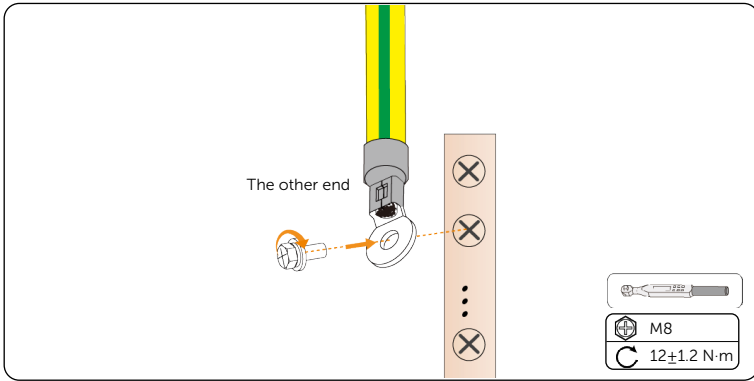

Figure 7-57 Connecting the other end of PE cable

7.2.2 Communication Cable Connection

The following takes a dual-rack battery system with 14 battery packs as an example, to show how to connect communication cables within the battery system.

Step 1: From right to left and top to bottom, connect the high-voltage box and the battery packs with short communication cables.

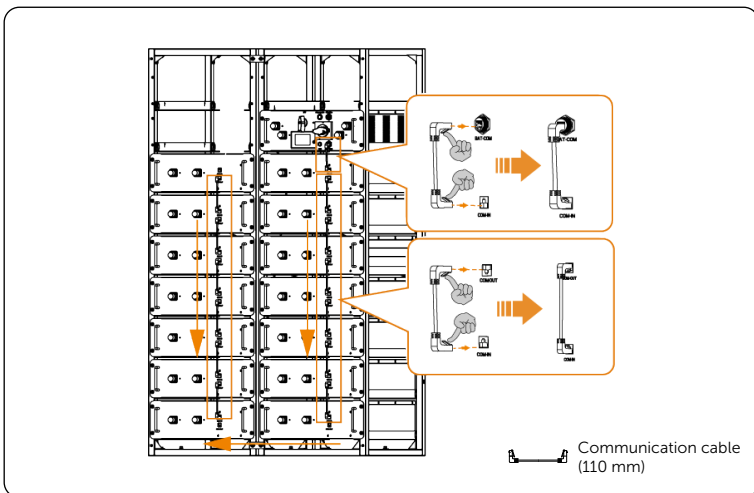

Figure 7-58 Connecting with short communication cables

- Step 2:** Connect port **COM-OUT** of the last pack on the right and port **COM-IN** of the first pack on the left with a long communication cable (part C4), which goes through the two racks. Fasten the cable to the horizontal support with a nylon tie (part L1).

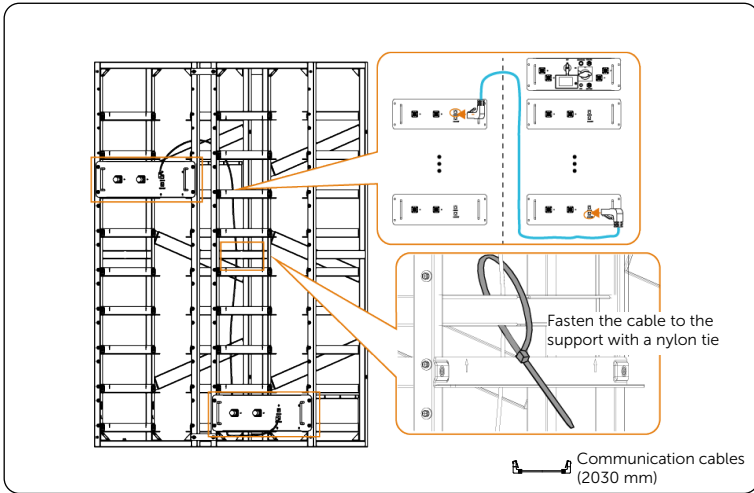

Figure 7-59 Connecting the other packs

- Step 3:** Insert the terminating resistor (part E2) into port **COM-OUT** of the last pack.

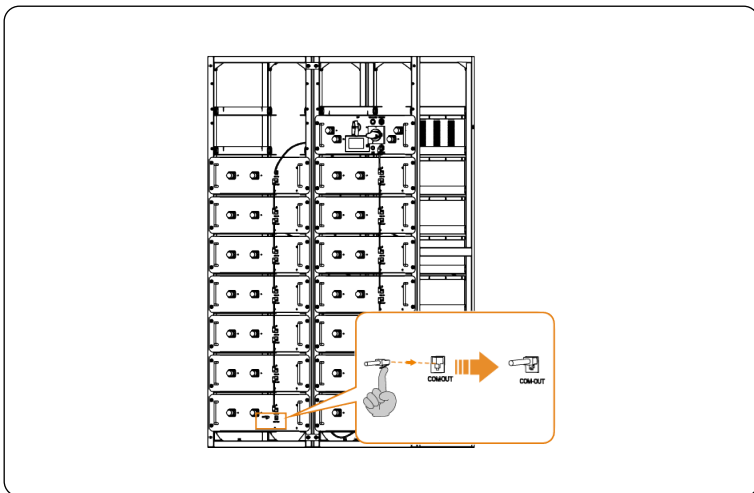

Figure 7-60 Inserting terminating resistor

7.2.3 Power cable connection



- When installing the power cable, connect the negative end first and then positive end, to ensure your personal safety.

Step 1: Take dust-proof covers down from all **B+** and **B-** ports of the battery system. Keep them properly for further use.

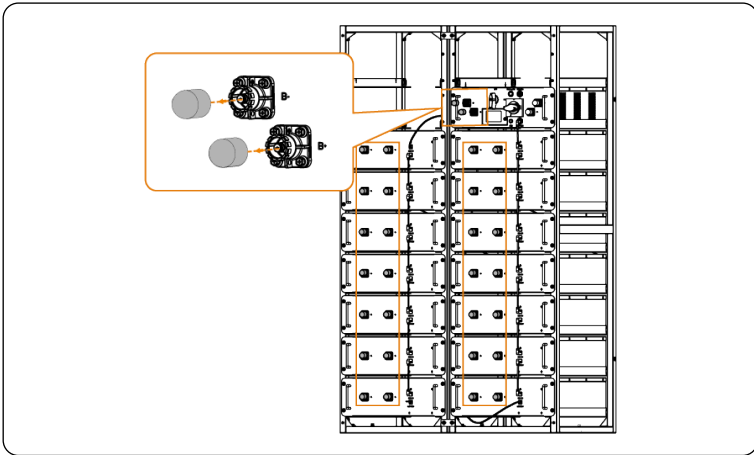

Figure 7-61 Taking dust-proof covers down

Step 2: Connect ports **B+** of the high-voltage box and its neighbouring battery pack with a power cable (part A2).



Figure 7-62 Connecting high-voltage box and pack

- Step 3:** In the direction shown in the figure, connect port **B-** of the first pack and port **B+** of the second pack with a power cable (part B3). Repeat the operation in the shown direction until you connect to port **B+** of the last pack.

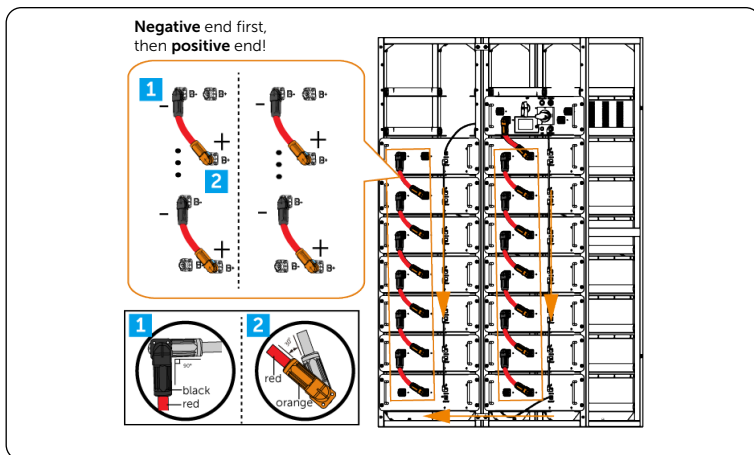

Figure 7-63 Connecting packs

- Step 4:** Thread the two long power cables (parts B2 and D4) through the two racks carefully, to avoid falling the MSD (Manual Shutdown Device) onto the ground.

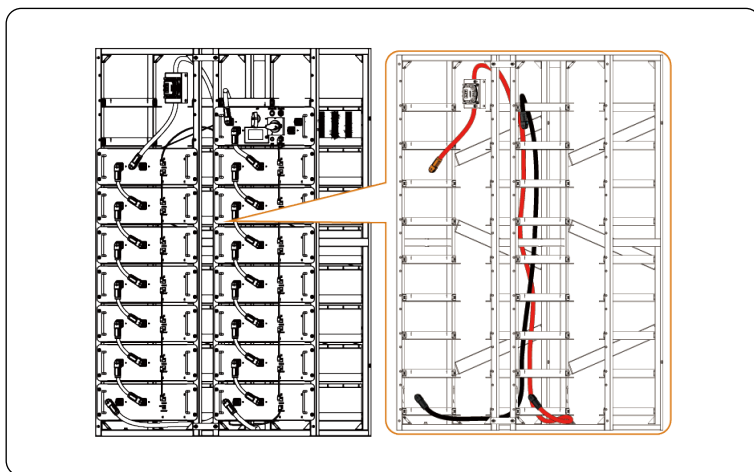

Figure 7-64 Threading power cables

Step 5: Install the MSD as shown below.

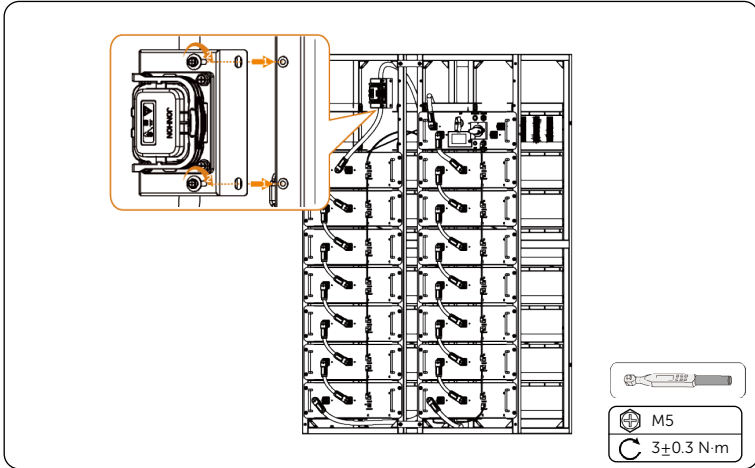

Figure 7-65 Fixing MSD onto rack

Step 6: Connect port **B-** of the high-voltage box and port **B-** of the last battery pack on the left with the power cable (part B2). Connect port **B-** of the last pack on the right to port **B+** of the first pack on the left with the power cable (part D4).

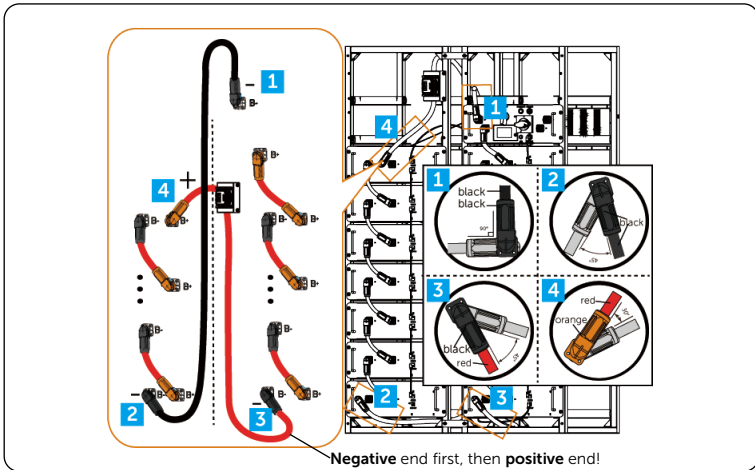

Figure 7-66 Connecting the remaining power ports

Step 7: Fasten the two long power cables to supports with nylon ties (part L1).

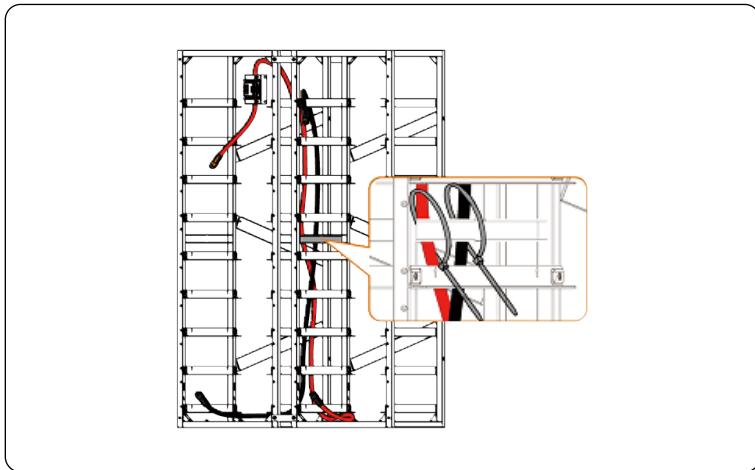

Figure 7-67 Fastening the long power cables

 **CAUTION!**

- During installation, do not remove the power cables forcibly. Otherwise, it will damage the cable connector. The correct removal method:



7.2.4 Connection to Inverter

Power cable connection

Step 1: Take dust-proof covers from ports **P+** and **P-** on the high-voltage box. Keep them properly for further use.

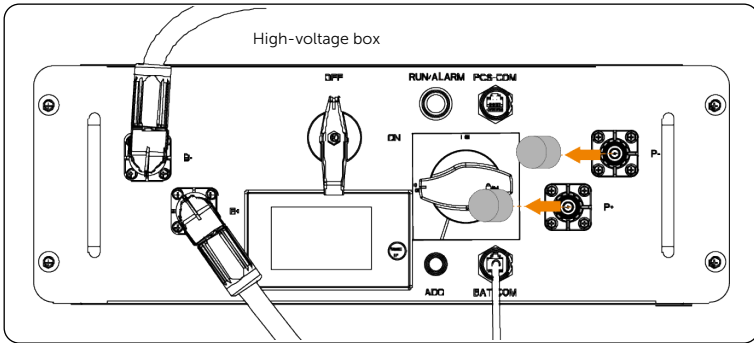

Figure 7-68 Taking dust-proof covers down

Step 2: Take positive and negative power cables (parts C2 and D2) from the accessory kit. Connect one end of the positive and negative power cables to ports **P+** and **P-** separately.

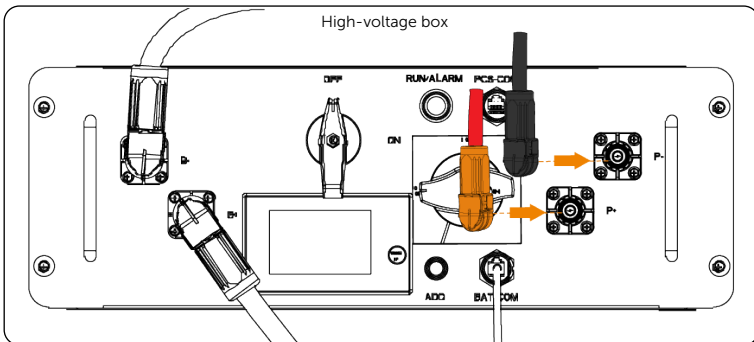

Figure 7-69 Connecting one end to battery

Step 3: Connect the other end of the positive and negative power cables to ports **BAT 1** and **BAT2** of the inverter.

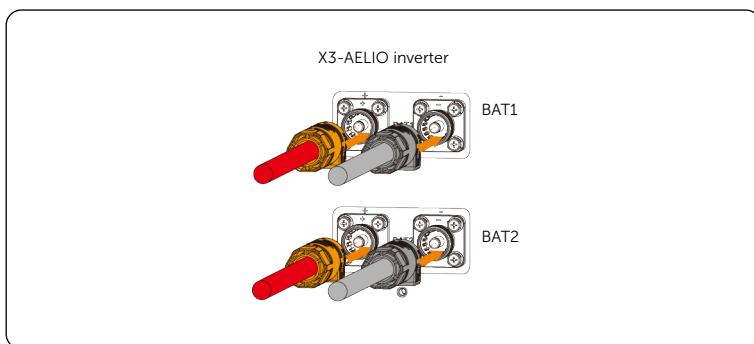

Figure 7-70 Connecting the other end to inverter

NOTICE!

- The power cables (parts C2 and D2), which are one-to-two cables, are only for one-battery-tower connection. For two-battery-tower parallel connection, use one-to-one power cables in the expansion capacity kit.

Communication cable connection

Step 1: Take the communication cable (part F2) from the accessory kit for high-voltage box. Connect one end of the cable to port **PCS COM** of the high-voltage box.

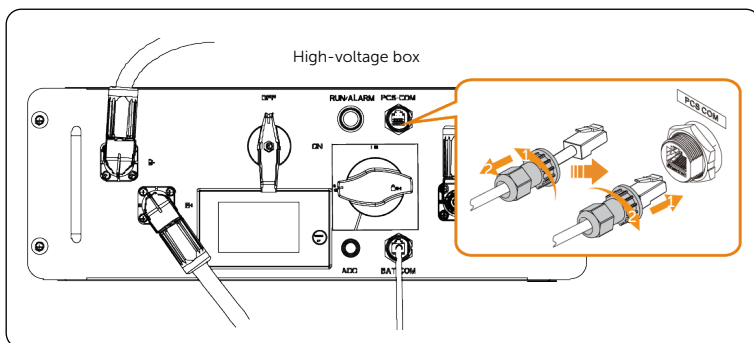

Figure 7-71 Connecting one end to battery

Step 2: Insert the other end of the cable into support **BMS1** or **BMS1** of port **COM1** on the inverter (take X3-AELIO inverter as an example).

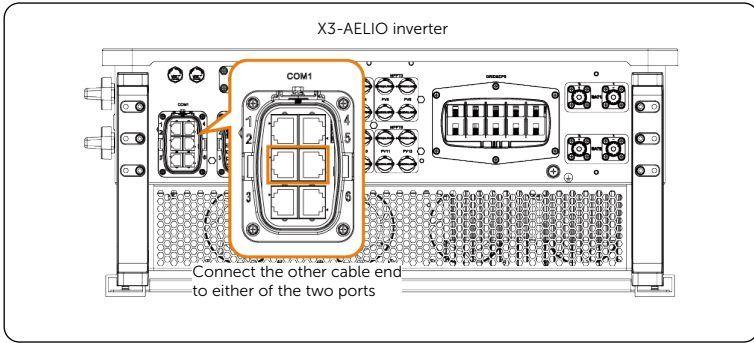

Figure 7-72 Connecting to inverter

NOTICE!

- For details about connecting to X3-AELIO inverter, see *X3-AELIO Series User Manual*.

Related operation

If the communication cable (part F2) we provide for you is not long enough, follow steps below to make one by yourself:

Step 1: Prepare a standard communication cable and an RJ-45. Cut the provided communication cable (part F2) to get the waterproof cap.

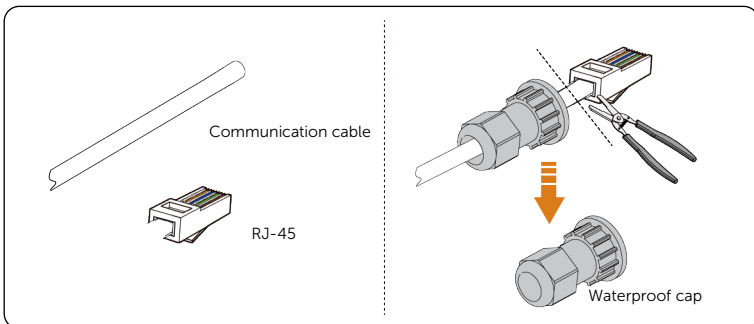

Figure 7-73 Preparing materials

Step 2: Thread the prepared communication cable through the waterproof. Strip the cable jacket off 15 mm.

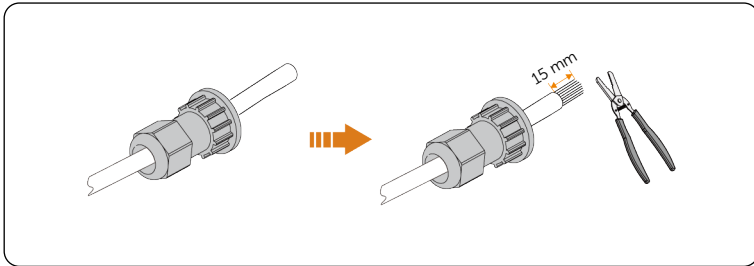

Figure 7-74 Stripping cable jacket

Step 3: To ensure pin-to-pin connection to the inverter, process one end of the cable according to the pin definition of battery communication port. Then thread cores into the RJ-45 and crimp them together.

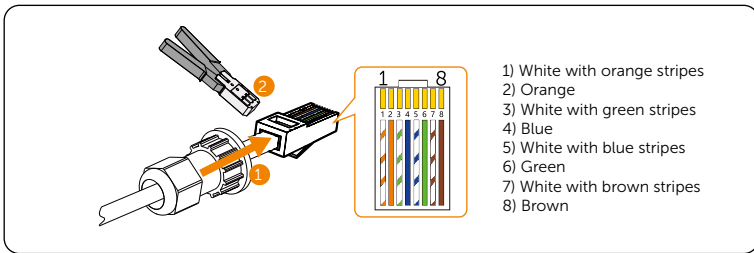

Figure 7-75 Crimping RJ45

Table 7-4 Pin assignment of battery port **PCS COM**

Pin No.	1	2	3	4	5	6	7	8
Definition	DO+	DO-	DI-	CANH	CANL	DI+	NC	NC

Step 4: Process the other end of the cable according to the pin definition of inverter communication port (take X3-AELIO inverter as an example). Then thread cores into the RJ-45 and crimp them together. For more details, see the corresponding inverter user manual.

Table 7-5 Pin assignment of inverter port **BMS** (X3-AELIO inverter)

Pin No.	1	2	3	4	5	6	7	8
Definition	BAT-TEMP	GND-COM	GND-COM	BMS1-CANH	BMS1-CANL	BAT_WAKEUP_POWER	BMS_485A	BMS_485B

8 System Commissioning

⚠ DANGER!

- Wear PPE and use insulated tools to avoid electric shocks or short circuits.

8.1 Checking before Powering On

- Check whether the device is installed correctly and securely;
- Make sure that the breaker is closed;
- All cables are connected correctly and securely;
- All unconnected ports are covered;
- The installation space is proper, and the installation environment is clean and tidy.

8.2 Power On

To start up a battery system, follow steps below:

Step 1: Rotate the battery switch to **ON**.

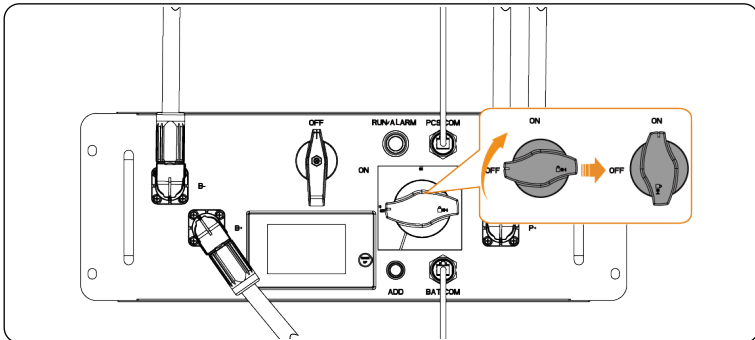

Figure 8-1 Turning on the battery switch

Step 2: Rotate the auxiliary power switch to **ON**, to supply power to or obtain power from the inverter.

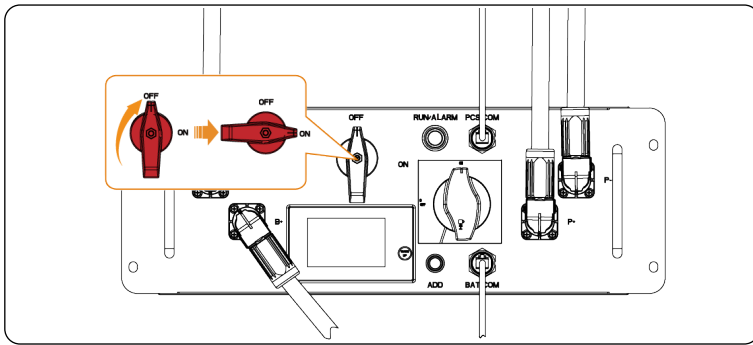

Figure 8-2 Turning on the auxiliary power switch

Step 3: **(Required for initial start or when the number of packs changes)** Long press the **ADD** key for more than 10s to allocate a communication address to each battery pack. At this time, if the **RUN/ALARM** indicator flashes green fast, it indicates that communication address assignment succeeds. When the indicator turns into "solid green", it indicates that address assignment ends.

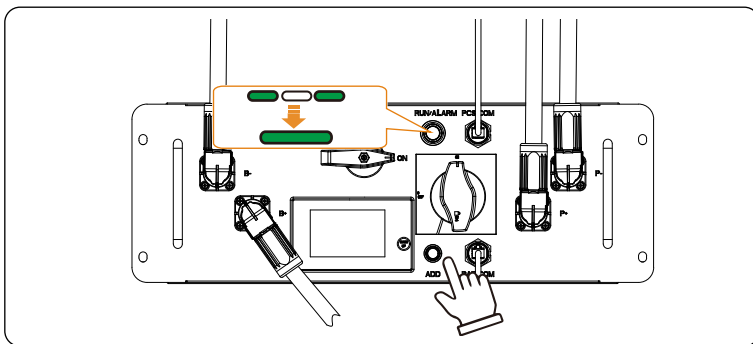

Figure 8-3 Enabling communication address assignment

NOTICE!

- A system problem might occur due to frequent pressing of the key. If it happens, please try again after 10s.
- Once the number of battery packs changes, please restart the battery system to reallocate the communication address to each battery pack.
- The communication addresses of battery packs are consistent with the sequence of serial connection of a battery tower.

Power Off

WARNING!

- Do not touch the battery until it has been turned off for at least 5 minutes. Otherwise, the residual power or heat will cause electric shocks or personal injuries.

After turning off the inverter, switch the battery system off as follows.

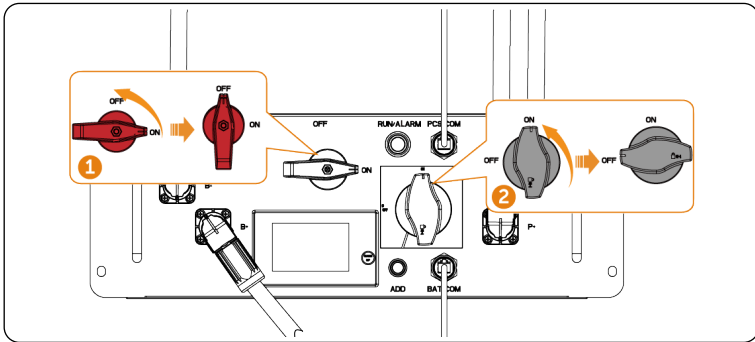

Figure 8-4 Powering off the battery system

NOTICE!

- For two battery towers connected in parallel, there is no sequential order for powering on or off them.

9 Capacity Expansion

DANGER!

- Wear PPE and use insulated tools to avoid electric shocks or short circuits.

There are two ways to expand the battery capacity:

- Adding battery packs if there is enough space for additional battery packs.
- Connecting two battery towers to an inverter in parallel if the inverter is permitted.

9.1 Adding Battery Packs

NOTICE!

- The added battery packs must be of the same model with the previous ones.
- The capacity difference between the new battery packs and the old battery packs cannot be more than 0.128 kWh.
- Ensure that the ground can bear the weight of the additionally added battery packs. For details, see "4.1.2 Installation Carrier Requirement".

To add a battery pack, follow steps below (take a single-rack battery system of 5 battery packs as an example):

Step 1: Power off the inverter to which the battery system is connected.

Step 2: Switch off the battery as shown below.

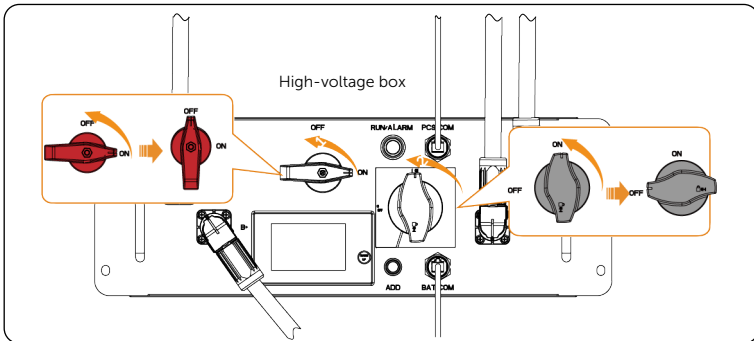

Figure 9-5 Powering off the battery system

Step 3: Remove all cables connected to the high-voltage box.

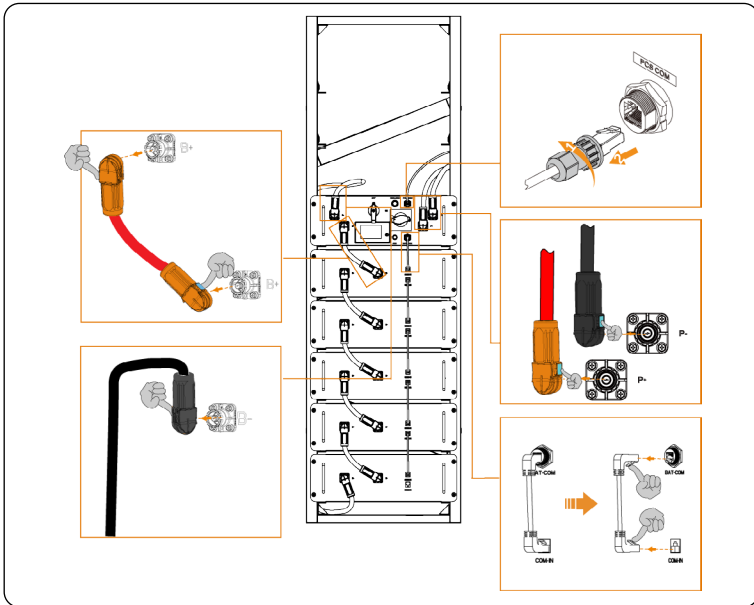

Figure 9-6 Unplugging all cables from high-voltage box

Step 4: Loosen screws on both sides of the high-voltage box. Pull the high-voltage box out of the rack with cooperation with another person and put it aside carefully, to avoid collision with the ground.

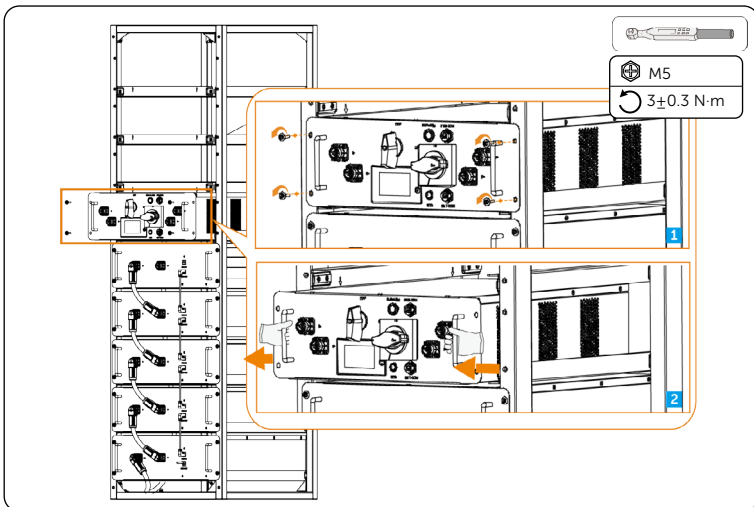

Figure 9-7 Taking high-voltage box down

- Step 5:** Dismantle the supports for the to-be-installed pack and high-voltage box. Install the supports in their reverse directions separately, to make the layer height proper for the pack and high-voltage box.

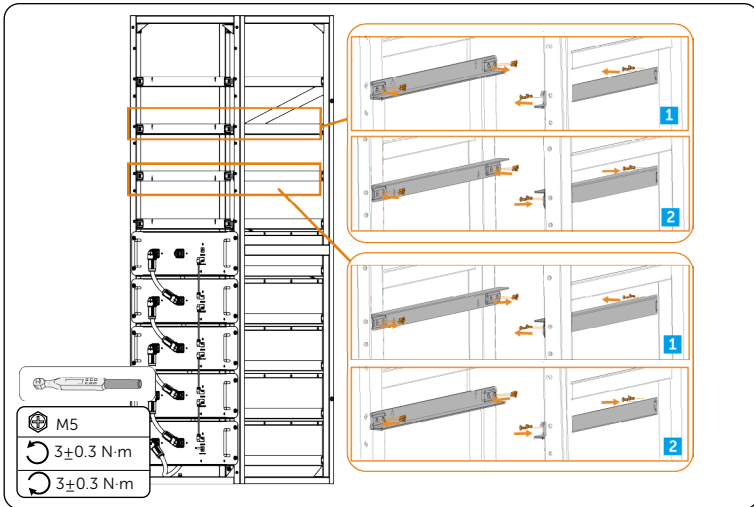

Figure 9-8 Adjusting the layer height by reinstalling supports

- Step 6:** Place the battery pack and high-voltage box into the rack and tighten screws on two sides of them.

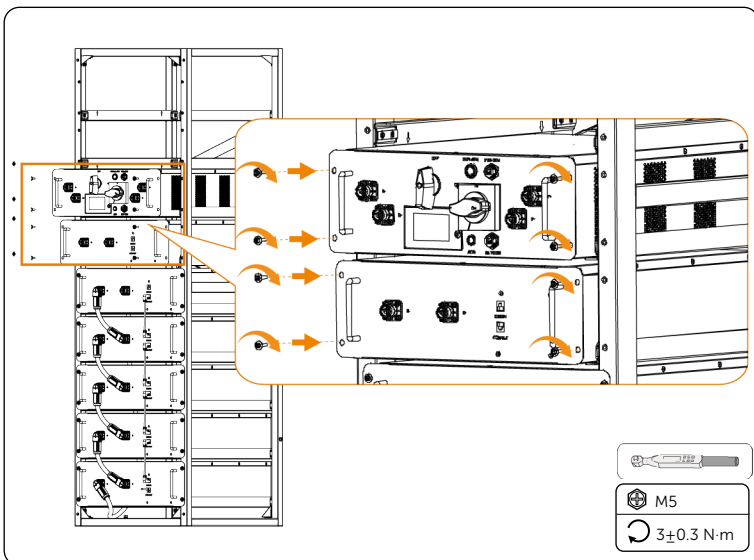

Figure 9-9 Placing battery pack and high-voltage box

- Step 7:** Connect cables to the battery pack and high-voltage box. For details, see "[6 Installation and Wiring for Single-Rack Battery System](#)".
- Step 8:** Switch on the battery. Long press the **ADD** key on the high-voltage box for more than 10s to assign communication addresses. For details, see "[8.2 Power On](#)".
- Step 9:** Enable the capacity expansion function on the inverter (take X3-AELIO inverter as an example). Two methods are available:
- On the inverter LCD, select **Setting > Advance Setting** and set **Extend BAT FUNC** to **Enable**.
 - On the SolaXCloud App, select your plant and find your inverter. Tap the inverter to enter its details page. In **Function control > Remote settings > Advance Setting > Extend BAT FUNC**, set **Extend BAT FUNC** to **Enable**.

NOTICE!

- The setting item name for capacity expansion may vary with the inverter model, for example **Extend BAT FUNC** for X3-AELIO inverter, but **Battery Capacity** for X3-HYB G4 PRO. The finally displayed name shall prevail.

9.2 Connecting Two Battery Towers to Inverter in Parallel

NOTICE!

- Different from one-tower battery system, the two-tower parallel battery system uses the one-to-one power cables (parts A5 and B5) in the expansion capacity kit to connect to the inverter.
- The two battery towers connected in parallel must be placed on two sides of the inverter.

Cables between the battery system and inverter are shown below.

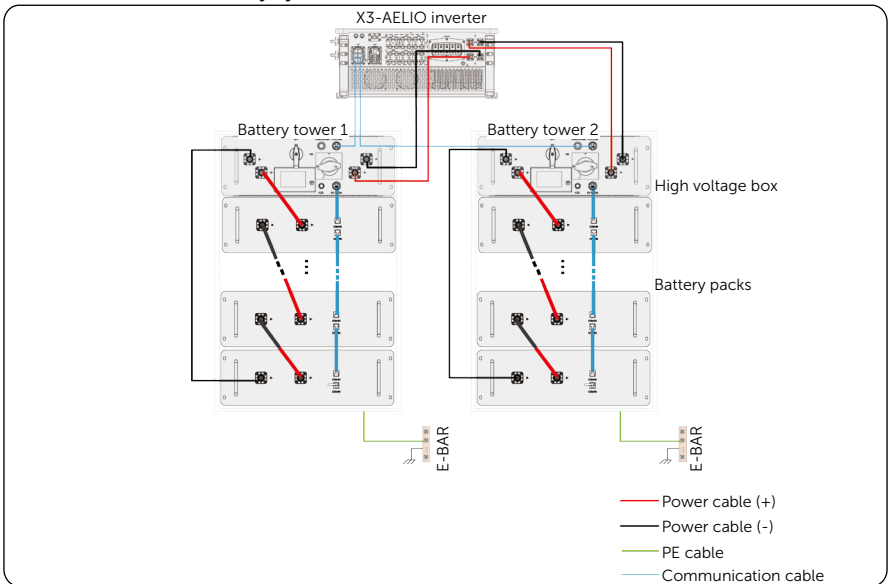

Figure 9-10 Wiring diagram of single-rack battery systems connected in parallel

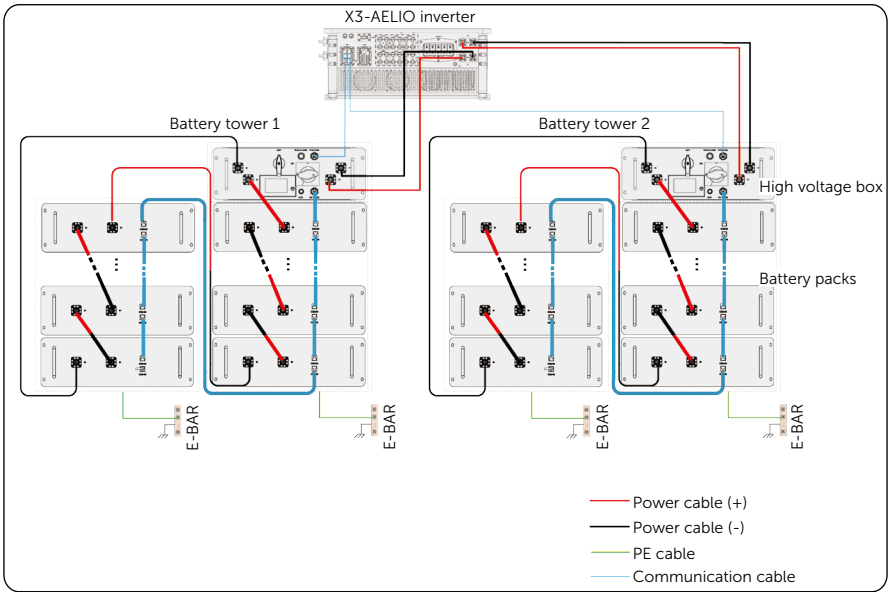

Figure 9-11 Wiring diagram of dual-rack battery systems connected in parallel

The wiring method for two-tower parallel connection is similar to that for single tower connection. For more details, see “6 Installation and Wiring for Single-Rack Battery System” or “7 Installation and Wiring for Dual-Rack Battery System”.

NOTICE!

After wiring, you further need to do:

1. Switch on the battery and then long press the **ADD** key on the high-voltage box for more than 10s to reallocate a communication address to each pack. For details, see “8.2 Power On”.

2. On the inverter LCD or SolaXCloud App, set **Extend BAT FUNC or Battery Capacity to Enable** in **Setting > Advance Setting**. For details, see the corresponding inverter manual.

10 Troubleshooting and Maintenance

10.1 Maintenance

Regular maintenance is required for the device. The table below lists the operational maintenance for expressing the optimum device performance. More frequent maintenance service is needed in the worse work environment. Please make records of the maintenance.

 **WARNING!**

- Only qualified person can perform the maintenance for the device.
- Wear PPE before conducting maintenance.

 **CAUTION!**

- The system must be powered off before conducting maintenance works, for instance, system cleaning, electrical connections, PE cable checks.

Table 10-1 Maintenance list

Check Item	Description	Period
Running status of the system	<ul style="list-style-type: none"> • Check whether there is any damage or deformation to the device. • Check whether there are any abnormal noise in the running system. 	Every 6 months
Electrical connections	<ul style="list-style-type: none"> • Check whether the cables are fastened securely. If not, please tighten them again according to the torque written in the document. • Check there is any damage to the cables, especially the cable jacket connecting with the metal parts. • Check whether the unconnected ports are covered. 	The first maintenance should be scheduled within half a year after the first commissioning, and then check them every 6-12 months.
PE cable checks	<ul style="list-style-type: none"> • Check whether the PE cable is firmly attached. 	The first maintenance should be scheduled within half a year after the first commissioning, and then check them every 6-12 months.

10.2 Troubleshooting

The following table shows the common fault codes and corresponding solutions.

For further assistance, contact SolaX Customer Service. Please provide the model and SN of the device, and be prepared to describe the system installation details.

Table 10-2 Troubleshooting information

Fault Code	Description	Solution
F01	Single-cell overvoltage level 4	Ignore it. The fault will be automatically cancelled when the cell voltage returns to normal.
F02	Single-cell overvoltage level 5	Ignore it. The fault will be automatically cancelled when the cell voltage returns to normal.
F03	Single-cell undervoltage level 4	Charge the battery in time.
F04	Single-cell undervoltage level 5	Charge the battery in time.
F05	Voltage difference fault	Contact our installer or distributor.
F06	Total voltage overvoltage level 4	Ignore it. The fault will be automatically cancelled when the cell voltage returns to normal.
F07	Total voltage overvoltage level 5	Ignore it. The fault will be automatically cancelled when the cell voltage returns to normal.
F08	Total voltage undervoltage level 4	Charge the battery in time.
F09	Total voltage undervoltage level 5	Charge the battery in time.
F10	Main positive relay adhesion	Contact our installer or distributor.
F11	Temperature too high	Ignore it. The fault will be automatically cancelled when the battery temperature returns to normal.
F12	Temperature sampling fault level 1	Contact our installer or distributor.
F13	Temperature sampling fault level 4	Contact our installer or distributor.
F14	Temperature too low	Ignore it. The fault will be automatically cancelled when the battery temperature returns to normal.

Fault Code	Description	Solution
F15	Discharge overcurrent fault level 4	Ignore it. The fault can be automatically solved.
F16	Discharge overcurrent fault level 5	Ignore it. The fault can be automatically solved.
F17	Charge overcurrent fault level 4	Ignore it. The fault can be automatically solved.
F18	Charge overcurrent fault level 5	Ignore it. The fault can be automatically solved.
F19	Internal communication fault	<ol style="list-style-type: none"> 1. Check whether the communication cable connection between the high-voltage and battery packs is correct and secure. If not, reconnect them securely. If yes, go to step 2. 2. Check whether the communication cables are broken. If not, contact our installer or distributor. If yes, replace the communication cables.
F20	External communication fault	<ol style="list-style-type: none"> 1. Check whether the communication cable connection between the high-voltage and inverter is correct and secure. If not, reconnect them securely. If yes, go to step 2. 2. Check whether the communication cable is broken. If not, contact our installer or distributor. If yes, replace the communication cable.
F21	Voltage sampling fails	Contact our installer or distributor.
F22	Voltage sensor fails	Re-assign the communication addresses to battery packs. If it doesn't work, contact our installer or distributor.
F23	Current sensor fails	Contact our installer or distributor.
F24	Main negative relay adhesion	Contact our installer or distributor.
F25	Flash fails	Contact our installer or distributor.
F26	No response to charge request	Charge the battery in time.
F27	Insulation fails	Contact our installer or distributor.
F28	Precharge fails	<ol style="list-style-type: none"> 1. Check whether the isolation switch is closed. 2. Contact our installer or distributor.
F29	Pack hardware protection fails	Contact our installer or distributor.

Fault Code	Description	Solution
F30	Self check fails	Re-assign the communication addresses to battery packs. If it doesn't work, contact our installer or distributor.
F31	Temperature of high-voltage connector too high level 3	Ignore it. The fault will be automatically cancelled when the temperature returns to normal.
F32	Temperature of high-voltage connector too high level 5	Ignore it. The fault will be automatically cancelled when the temperature returns to normal.
F33	Temperature of post terminal too high	Contact our installer or distributor.
F34	Single-cell undervoltage level 1	Charge the battery in time.
F35	Total voltage undervoltage level 4	Charge the battery in time.

11 Decommissioning

11.1 Disassembly of Cables

⚠ WARNING!

- Only the qualified personnel can perform disassembly of cables.
- To avoid electric shocks, use insulated tools and wear individual protective tools.

Here take one-rack battery system as an example, to show how to disassembly cables.

Step 1: Turn off the inverter to which the battery is connected.

Step 2: Switch off the battery as shown below.

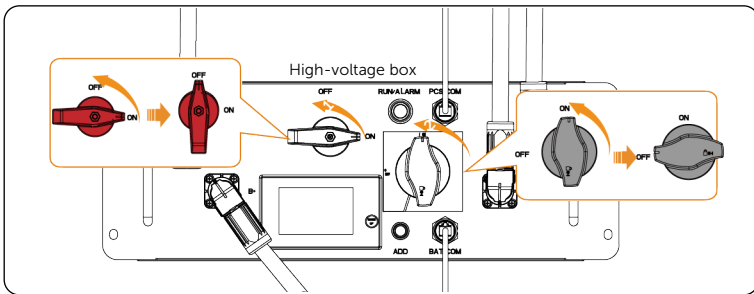

Figure 11-12 Powering off battery system

Step 3: Remove all cables from the high-voltage box.

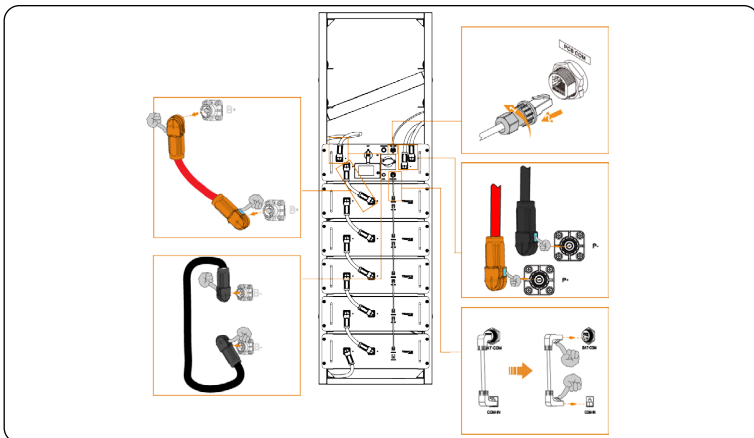

Figure 11-13 Unplugging all cables from high-voltage box

Step 4: Unplug communication cables within the battery system.

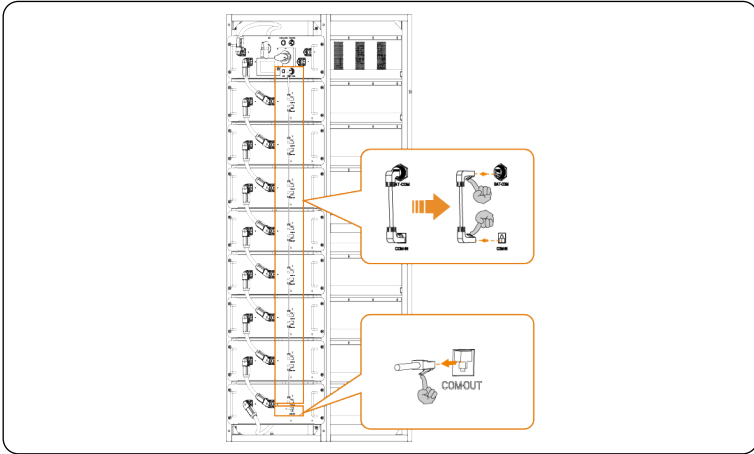

Figure 11-14 Unplugging communication cables within battery

Step 5: Unplug power cables within the battery system.

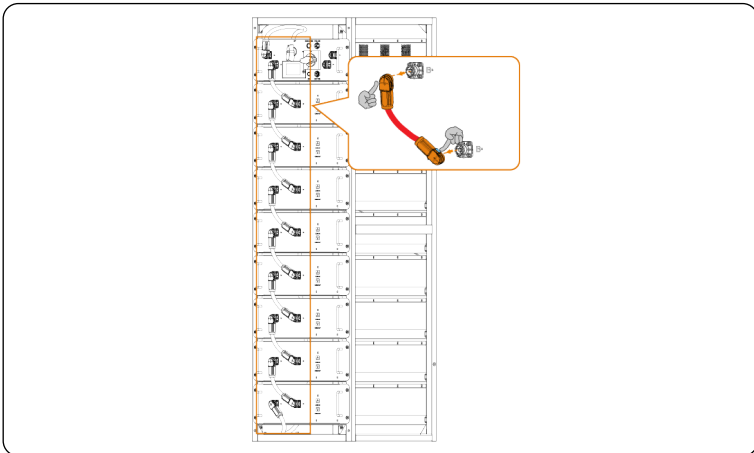

Figure 11-15 Unplugging power cables within battery

Step 6: Disassemble the PE cable from the rack.

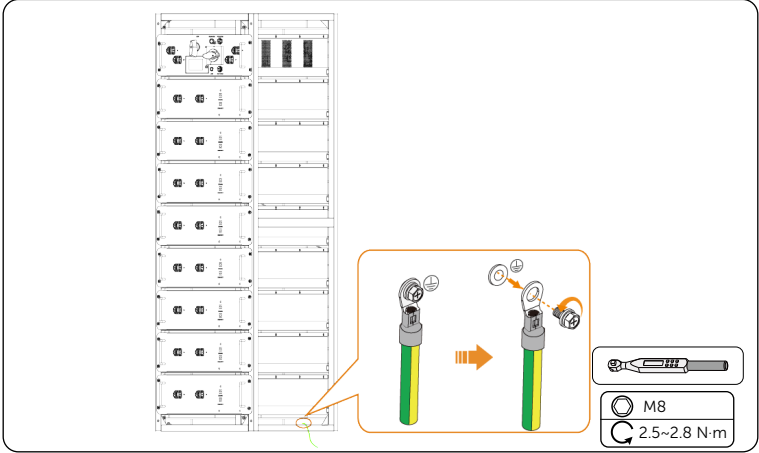

Figure 11-16 Disassembling PE cable

11.2 Packing

- If the original packing material is available, package the high-voltage box, battery packs, and battery rack with the original package.
- If the original packing material is unavailable, package them with the packing material which meets the following requirements:
 - » Suitable for the weight of product;
 - » Easy to carry;
 - » Be capable of being closed completely.

12 Technical Data

CONFIGURATION LIST

No.	Model	High-voltage box	Battery pack
1	T-HR38.4 / T-HR38.4P ¹	TBMS-R76x1	TB-HR76x5
2	T-HR46.0 / T-HR46.0P	TBMS-R76x1	TB-HR76x6
3	T-HR53.7 / T-HR53.7P	TBMS-R76x1	TB-HR76x7
4	T-HR61.4 / T-HR61.4P	TBMS-R76x1	TB-HR76x8
5	T-HR69.2 / T-HR69.2P	TBMS-R76x1	TB-HR76x9
6	T-HR76.8 / T-HR76.8P	TBMS-R76x1	TB-HR76x10
7	T-HR84.4 / T-HR84.4P	TBMS-R76x1	TB-HR76x11
8	T-HR92.1 / T-HR92.1P	TBMS-R76x1	TB-HR76x12
9	T-HR99.8 / T-HR99.8P	TBMS-R76x1	TB-HR76x13
10	T-HR107.5 / T-HR107.5P	TBMS-R76x1	TB-HR76x14

BATTERY SYSTEM

TSYS-HR76					
Item	Module	T-HR38.4 / T-HR38.4P	T-HR46.0 / T-HR46.0P	T-HR53.7 / T-HR53.7P	T-HR61.4 / T-HR61.4P
Module quantity		5	6	7	8
Nominal energy (kWh)		38.4	46.0	53.7	61.4
Usable energy (90% DOD) (kWh)		34.5	41.4	48.3	55.2
Nominal voltage (d.c. V)		256	307.2	358.4	409.6
Operating voltage range (d.c. V)		200~292	240~350.4	280~408.8	320~467.2
Recommended charge / discharge current ² (d.c. A)		90			
Max. charge / discharge current ² (d.c. A)		150			
Rated power (kW)		23.0	27.6	32.2	36.8

TSYS-HR76							
Item	Module	T-HR69.2 / T-HR69.2P	T-HR76.8 / T-HR76.8P	T-HR84.4 / T-HR84.4P	T-HR92.1 / T-HR92.1P	T-HR99.8 / T-HR99.8P	T-HR107.5 / T-HR107.5P
Module quantity		9	10	11	12	13	14
Nominal energy (kWh)		69.1	76.8	84.4	92.1	99.8	107.5
Usable energy (90% DOD) (kWh)		62.2	69.1	76.0	82.9	89.8	96.7
Nominal voltage (d.c. V)		460.8	512	563.2	614.4	665.6	716.8
Operating voltage range (d.c. V)		360~525.6	400~584	440~642.4	480~700.8	520~759.2	560~817.6
Recommended charge / discharge current ² (d.c. A)		90					
Max. charge / discharge current (d.c. A)		150					
Rated power (kW)		41.4	46.0	50.6	55.2	59.8	64.5

BATTERY MODULE

Battery model	TB-HR76
Nominal energy (kWh)	7.68
Nominal voltage (d.c. V)	51.2
Rated capacity (Ah)	150
Cycle life (90% DOD)	≥ 6000 (@25°C ± 2°C, 0.5C / 0.5C, 70% EOL)
Battery type	LFP
Dimensions (W x H x D) (mm)	450 x 170 x 580
Weight (kg)	60

BMS

BMS model	TBMS-R76
Dimensions (W x H x D) (mm)	450 x 180 x 580
Weight (kg)	19.2

RACK

Parameter	Model	T-HR 38.4	T-HR 46.0	T-HR 53.7	T-HR 61.4	T-HR 69.2	T-HR 76.8	T-HR 84.4	T-HR 92.1	T-HR 99.8	T-HR 107.5	
Dimensions (W x H x D) (mm)		530 X 1800 X 600					1110 X 1800 X 600					
Weight (kg)		38.5					77					

RACK WITH PROTECTIVE COVER

Parameter	Model	T-HR 38.4P	T-HR 46.0P	T-HR 53.7P	T-HR 61.4P	T-HR 69.2P	T-HR 76.8P	T-HR 84.4P	T-HR 92.1P	T-HR 99.8P	T-HR 107.5P	
Dimensions (W x H x D) (mm)		530 X 1800 X 692					1130 X 1800 X 692					
Weight (kg)		77.5					155					

GENERAL SPECIFICATION

Battery roundtrip efficiency (0.5C / 0.5C, 25°C)	95%
Operating temperature range ² (°C)	0 to 55 (Charge) -20 to 55 (Discharge)
Communication interfaces	CAN
Installation type	Rack Mounting
Relative humidity	5~85%
Max. operating altitude (m)	3000
Environment	Indoor
Safety	IEC 62619, IEC 60730, IEC 63056, IEC 61000
Transport testing requirement	UN38.3

¹The models with "P" are battery systems delivered with rack protective cover. For details about cover installation, see *Installation Guide for TSYS-HR76 Rack with Protective Cover*.

²It is affected by temperature and SOC.



SolaX Power Network Technology (Zhejiang) Co., Ltd.

Add.: No. 278, Shizhu Road, Chengnan Sub-district, Tonglu County,
Hangzhou, Zhejiang, China
E-mail: info@solaxpower.com